



A5U1GA31ABF
A5U1GA31ATS/A5U1GA41ATS
128M x 8bit / 64M x 16bit NAND Flash Memory

1Gb SLC NAND Flash Specification

A5U1GA31ABF
A5U1GA31ATS
A5U1GA41ATS



Zentel Electronics Corp.

GENERAL DESCRIPTION

Offered in 128Mx8 / 64Mx16 bits, this device is 1Gbit with spare 32Mbit capacity. The device is offered in 3.3V V_{CC}. Its NAND cell provides the most cost effective solution for the solid state mass storage market. A program operation can be performed in typical 200us on the 2,112-byte(x8) or 1,056-word(x16) page and an erase operation can be performed in typical 1.5ms on a (128K+4K) bytes(x8) or (64K+2K) words(x16) block. Data in the data register can be read out at 25ns cycle time per byte(x8) or word(x16). The I/O pins serve as the ports for address and data input/output as well as command input. The on-chip write controller automates all program and erase functions including pulse repetition, where required, and internal verification and margining of data. Even the write-intensive systems can take advantage of this device's extended reliability of 100K program/erase cycles by providing ECC (Error Correcting Code) with real time mapping-out algorithm.

This device is an optimum solution for large nonvolatile storage applications such as solid state file storage and other portable applications requiring non-volatility.

FEATURES

- Voltage Supply:
 - 3.3V Device: 2.7 V ~ 3.6V
- Operating Temperature:
 - Commercial: 0 ~ 70°C
 - Extended: -25 ~ 85°C
 - Industrial: -40 ~ 85°C
- Organization
 - Memory Cell Array: (128M + 4M) x 8bit / (64M + 2M) x 16bit
 - Data Register: (2K + 64) x 8bit / (1K + 32) x 16bit
- Automatic Program and Erase
 - Page Program: (2K + 64) bytes / (1K + 32) words
 - Block Erase: (128K + 4K) bytes / (64K + 2K) words
- Page Read Operation
 - Page Size: (2K + 64) bytes / (1K + 32) words
 - Random Read: 25us (Max.)
 - Serial Access: 25ns (Min.)
- Memory Cell: 1bit/Memory Cell
- Fast Write Cycle Time
 - Program time: 200us (Typ.)
 - Block Erase time: 1.5ms (Typ.)
- Command/Address/Data Multiplexed I/O Port
- Hardware Data Protection
 - Program/Erase Lockout During Power Transitions
- Reliable CMOS Floating Gate Technology
- Endurance:
 - 100K Program/Erase Cycles (with 1 bit/528 bytes ECC)
 - Data Retention: 10 Years
- Command Driven Operation
- Cache Program Operation for High Performance Program
- Copy-Back Operation
- Unique ID for Copyright Protection
- Package: Pb-FREE 48-Pin TSOP I
Pb-FREE BGA 63Ball (9x11/0.8mm pitch)

Zentel Electronics Corporation reserve the right to change products or specification without notice.

PRODUCT LIST

Part Number	VCC Range	Organization	PKG Type
A5U1GA31ABF-BC	2.7V ~ 3.6V	128M x8	FBGA 63 ball
A5U1GA31ATS-BC	2.7V ~ 3.6V	128M x8	TSOP I
A5U1GA41ATS-BC	2.7V ~ 3.6V	64M x16	TSOP I

Part Number

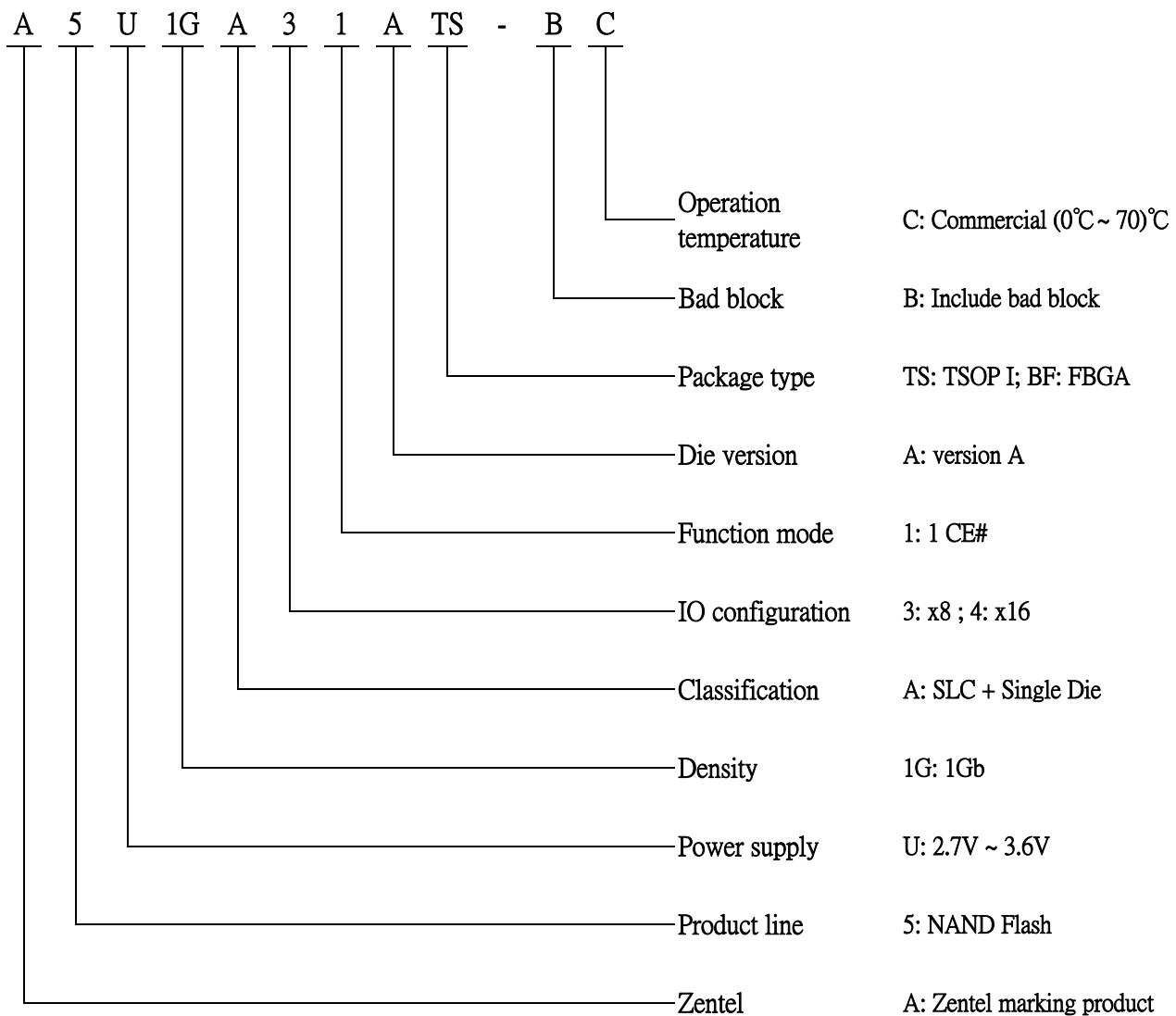

PIN ASSIGNMENT

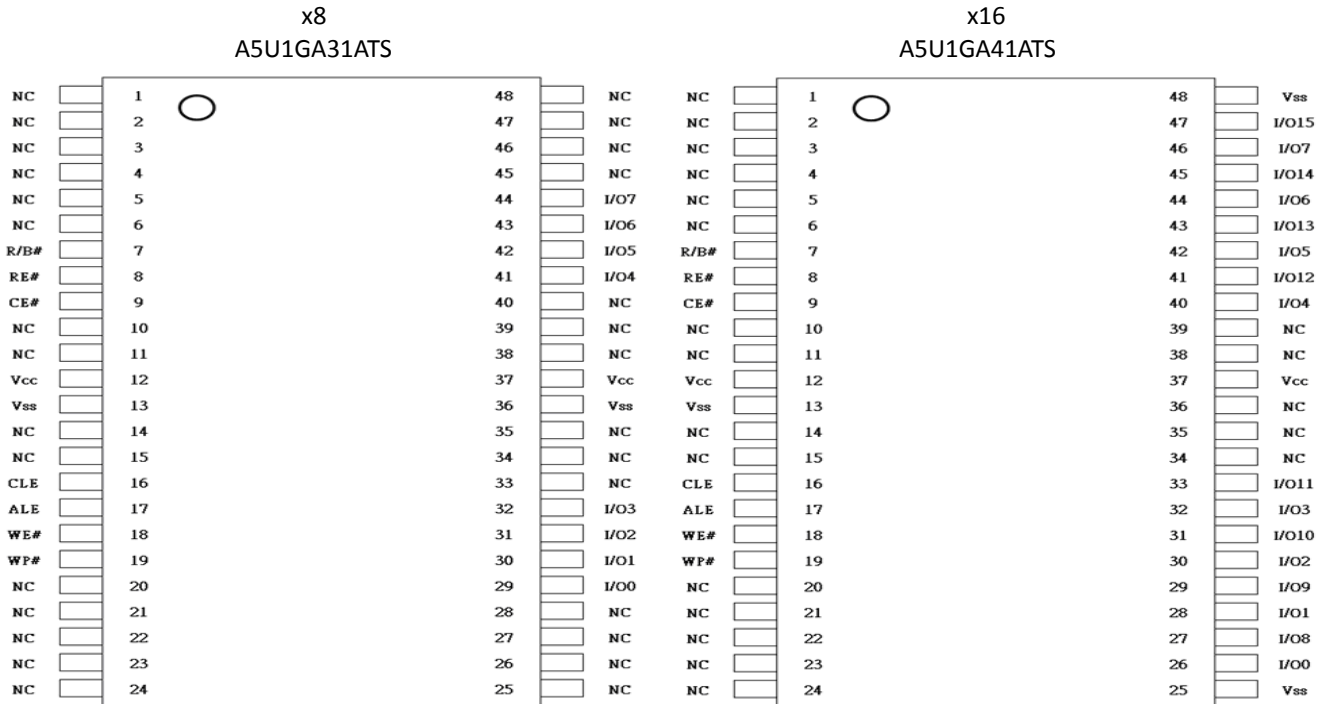

x8
A5U1GA31ABF

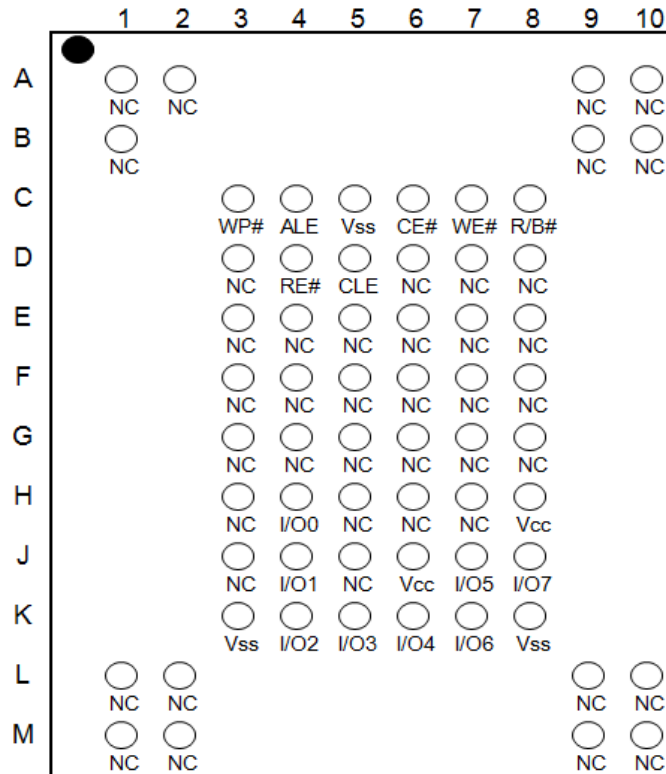

(TOP View)

PIN DISCRIPTION

Pin Name	Pin Function
I/O0 ~ I/O7	DATA INPUTS/OUTPUTS The I/O pins are used to input command, address and data and to output data during read operations. The I/O pins float to Hi-Z when the chip is deselected or when the outputs are disabled.
I/O8 ~ I/O15 ⁽²⁾	DATA INPUTS/OUTPUTS The I/O pins are used to input command, address and data and to output data during read operations. The I/O pins float to Hi-Z when the chip is deselected or when the outputs are disabled.
CLE	COMMAND LATCH ENABLE The CLE input controls the activating path for commands sent to the command register. When active high, commands are latched into the command register through the I/O ports on the rising edge of the WE# signal.
ALE	ADDRESS LATCH ENABLE The ALE input controls the activating path for address to the internal address registers. Addresses are latched on the rising edge of WE# with ALE high.
CE#	CHIP ENABLE The CE# input is the device selection control. When the device is in the Busy state, CE# high is ignored, and the device does not return to standby mode.
RE#	READ ENABLE The RE# input is the serial data-out control, and when active drives the data onto the I/O bus. Data is valid t_{REA} after the falling edge of RE# which also increments the internal column address counter by one.
WE#	WRITE ENABLE The WE# input controls writes to the I/O port. Commands, address and data are latched on the rising edge of the WE# pulse.
WP#	WRITE PROTECT The WP# pin provides inadvertent program/erase protection during power transitions. The internal high voltage generator is reset when the WP# pin is active low.
R/B#	READY/BUSY OUTPUT The R/B# output indicates the status of the device operation. When low, it indicates that a program, erase or random read operation is in process and returns to high state upon completion. It is an open drain output and does not float to Hi-Z condition when the chip is deselected or when outputs are disabled.
V _{CC}	POWER V _{CC} is the power supply for device.
V _{SS}	GROUND
N.C.	NO CONNECTION Lead is not internally connected.

Note:

1. Connect all V_{CC} and V_{SS} pins of each device to common power supply outputs. Do not leave V_{CC} or V_{SS} disconnected.
2. I/O8 ~ I/O15 are only defined within A5U1GA41ATS and must keep Low while input address or command cycle.

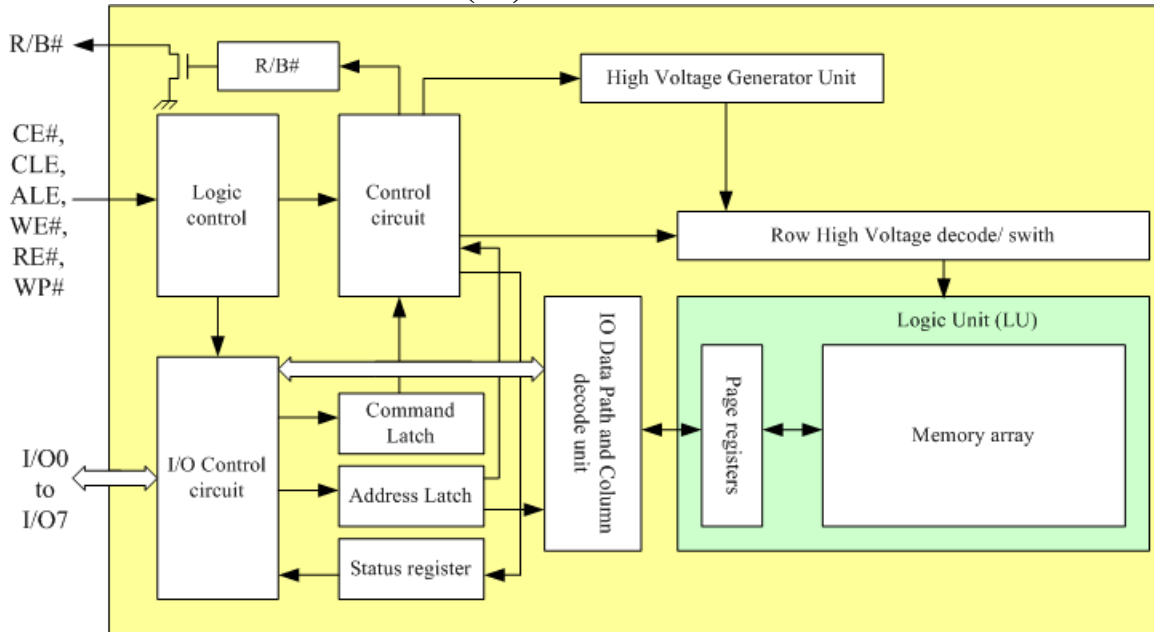
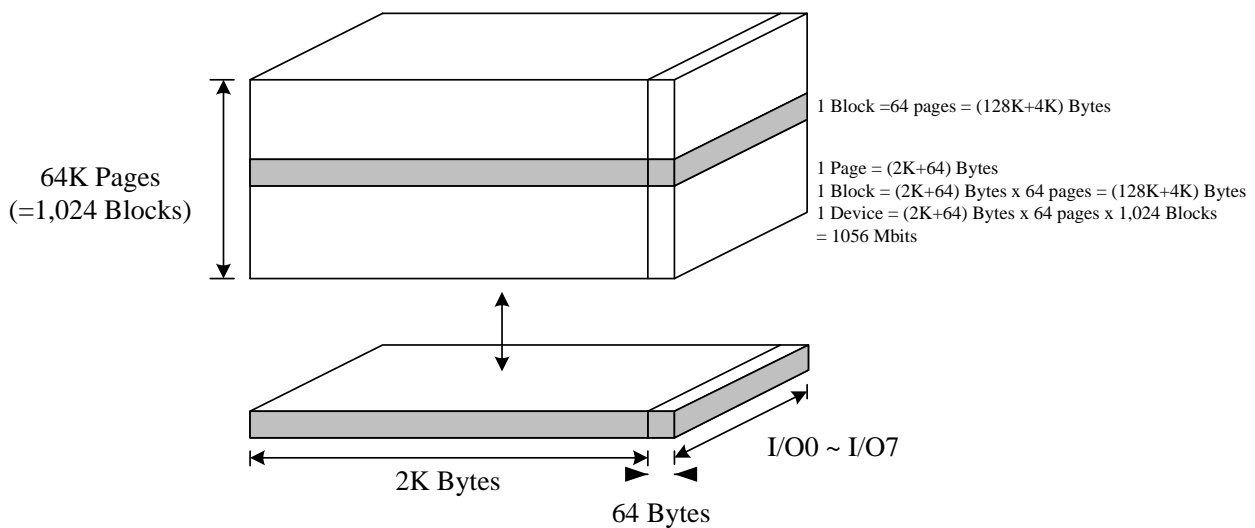
FUNCTION BLOCK DIAGRAM(x8)

ARRAY ORGANIZATION(x8)

Address Cycle Map(x8)

	I/O0	I/O1	I/O2	I/O3	I/O4	I/O5	I/O6	I/O7	
1st Cycle	A ₀	A ₁	A ₂	A ₃	A ₄	A ₅	A ₆	A ₇	Column Address
2nd Cycle	A ₈	A ₉	A ₁₀	A ₁₁	L *	L *	L *	L *	Column Address
3rd Cycle	A ₁₂	A ₁₃	A ₁₄	A ₁₅	A ₁₆	A ₁₇	A ₁₈	A ₁₉	Row Address
4th Cycle	A ₂₀	A ₂₁	A ₂₂	A ₂₃	A ₂₄	A ₂₅	A ₂₆	A ₂₇	(Page Address)

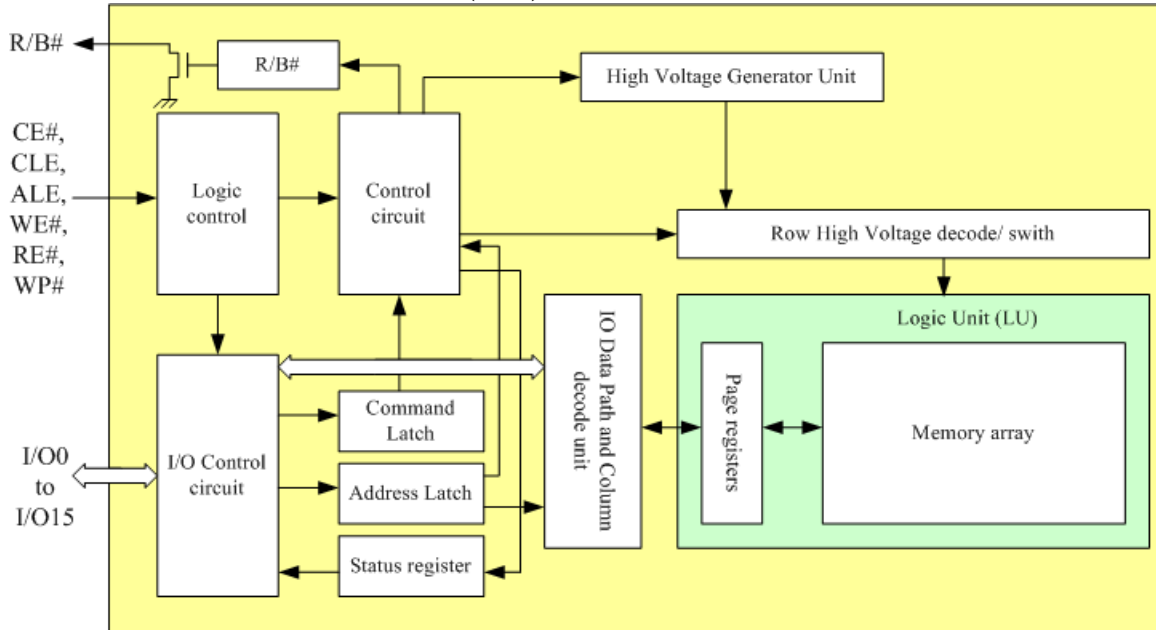
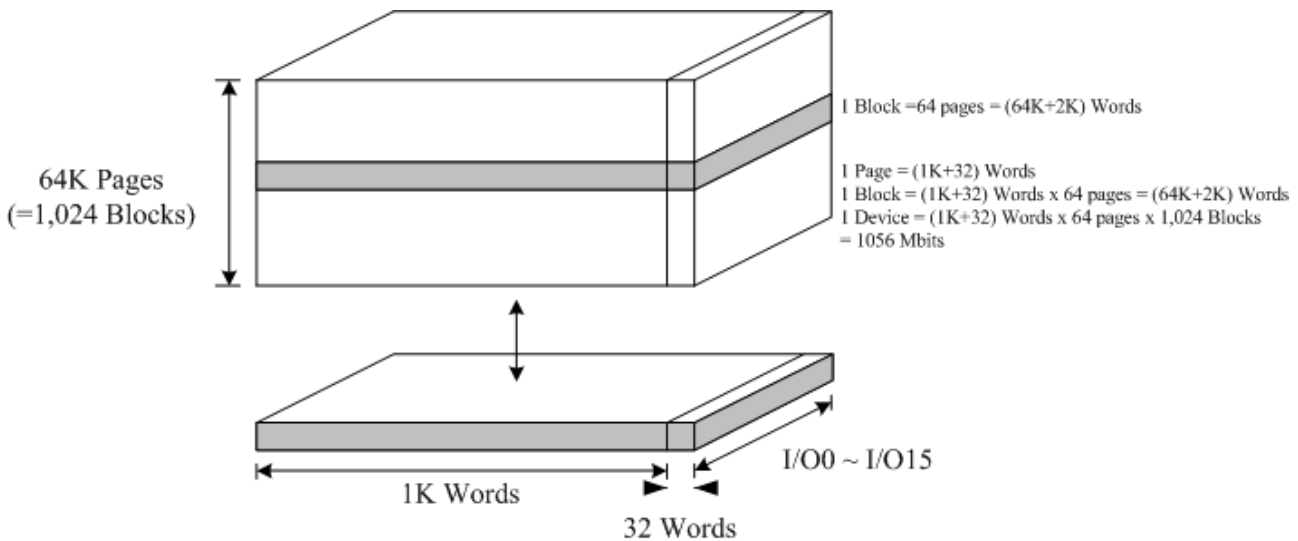
Note:

1. Column Address: Starting Address of the Register.
2. *L must be set to "Low"
3. *The device ignores any additional input of address cycles than required.

FUNCTION BLOCK DIAGRAM(x16)

ARRAY ORGANIZATION(x16)

Address Cycle Map(x16)

	I/O0	I/O1	I/O2	I/O3	I/O4	I/O5	I/O6	I/O7	
1st Cycle	A ₀	A ₁	A ₂	A ₃	A ₄	A ₅	A ₆	A ₇	Column Address
2nd Cycle	A ₈	A ₉	A ₁₀	L *	L *	L *	L *	L *	Column Address
3rd Cycle	A ₁₁	A ₁₂	A ₁₃	A ₁₄	A ₁₅	A ₁₆	A ₁₇	A ₁₈	Row Address
4th Cycle	A ₁₉	A ₂₀	A ₂₁	A ₂₂	A ₂₃	A ₂₄	A ₂₅	A ₂₆	(Page Address)

Note:

1. Column Address: Starting Address of the Register.
2. *L must be set to "Low"
3. *The device ignores any additional input of address cycles than required.



Product Introduction

This device is a 1,056Mbits (1,107,296,256 bits) memory organized as 65,536 rows (pages) by 2,112-byte(x8) or 1,056-word(x16) columns. Spare 64-byte(x8) or 32-word(x16) columns are located from column address of 2,048 to 2,111(x8) or 1,024 to 1,055(x16). A 2,112-byte(x8) or 1,056-word(x16) data register and 2,112-byte(x8) or 1,056-word(x16) cache register are serially connected to each other. Those serially connected registers are connected to memory cell arrays for accommodating data transfer between the I/O buffers and memory cells during page read and page program operations. The memory array is made up of 32 cells that are serially connected to form a NAND structure. Each of the 32 cells resides in a different page. A block consists of two NAND structured strings. A NAND structure consists of 32 cells. Total 1,081,344 NAND cells reside in a block. The program and read operations are executed on a page basis, while the erase operation is executed on a block basis. The memory array consists of 1,024 separately erasable 128K-byte(x8) or 64K-word(x16) blocks. It indicates that the bit by bit erase operation is prohibited on the device.

This device uses addresses multiplexed scheme. This scheme dramatically reduces pin counts and allows systems upgrades to future densities by maintaining consistency in system board design. Command, address and data are all written through I/O's by bringing WE# to low while CE# is low. Those are latched on the rising edge of WE#. Command Latch Enable (CLE) and Address Latch Enable (ALE) are used to multiplex command and address respectively, via the I/O pins. Some commands require one bus cycle. For example, Reset Command, Status Read Command, etc require just one cycle bus. Some other commands, like page read and block erase and page program, require two cycles: one cycle for setup and the other cycle for execution. The total physical space requires 28(x8) or 27(x16) addresses, thereby requiring four cycles for addressing: 2 cycle of column address, 2 cycles of row address, in that order. Page Read and Page Program need the same four address cycles following the required command input. In Block Erase operation, however, only the 2 cycles of row address are used. Device operations are selected by writing specific commands into the command register. Below table defines the specific commands of this device.

The device provides cache program in a block. It is possible to write data into the cache registers while data stored in data registers are being programmed into memory cells in cache program mode. The program performance may be dramatically improved by cache program when there are lots of pages of data to be programmed.

In addition to the enhanced architecture and interface, the device incorporates copy-back program feature from one page to another page without need for transporting the data to and from the external buffer memory. Since the time-consuming serial access and data-input cycles are removed, system performance for solid-state disk application is significantly increased.

Command Set

Function	1 st Cycle	2 nd Cycle	Acceptable Command during Busy
Read	00h	30h	
Read for Copy Back	00h	35h	
Read ID	90h	-	
Reset	FFh	-	O
Page Program	80h	10h	
Cache Program	80h	15h	
Copy-Back Program	85h	10h	
Block Erase	60h	D0h	
Random Data Input ⁽¹⁾	85h	-	
Random Data Output ⁽¹⁾	05h	E0h	
Read Status	70h	-	O

Note:

1. Random Data Input/ Output can be executed in a page.

Caution:

Any undefined command inputs are prohibited except for above command set of above table.

ABSOLUTE MAXIMUM RATINGS

Parameter	Symbol	Rating	Unit
Voltage on any pin relative to V _{SS}	V _{CC}	-0.6 to +4.6	V
	V _{IN}	-0.6 to V _{CC} +0.3(<4.6)	
	V _{IO}		
Temperature Under Bias	Commercial	T _{BIAS}	°C
	Extended		
	Industrial		
Storage Temperature	Commercial	T _{STG}	°C
	Extended		
	Industrial		
Short Circuit Current	I _{OS}	5	mA

Note:

- Minimum DC voltage is -0.6V on input/output pins. During transitions, this level may undershoot to -2.0V for periods <30ns. Maximum DC voltage on input/output pins is V_{CC}+0.3V which, during transitions, may overshoot to V_{CC}+2.0V for periods <20ns.
- Permanent device damage may occur if ABSOLUTE MAXIMUM RATINGS are exceeded. Functional operation should be restricted to the conditions as detailed in the operational sections of this data sheet. Exposure to absolute maximum rating conditions for industrial periods may affect reliability.

RECOMMENDED OPERATING CONDITIONS

(Voltage reference to GND, Commercial: TA=0 to 70°C, Extended: TA=-25 to 85°C, Industrial: TA=-40 to 85°C)

Parameter	Symbol	Min.	Typ.	Max.	Unit
Supply Voltage	V _{CC}	2.7	3.3	3.6	V
Supply Voltage	V _{SS}	0	0	0	V

DC AND OPERATION CHARACTERISTICS

(Recommended operating conditions otherwise noted)

Parameter	Symbol	Test Conditions	A5U1GA31ABF A5U1GA31ATS A5U1GA41ATS			Unit	
			Min.	Typ.	Max.		
Operating Current	Sequential Read	I _{CC1}	t _{RC} =25ns, CE#=V _{IL} , I _{OUT} =0mA	-	15	30	mA
	Program	I _{CC2}	-	-	15	30	
	Erase	I _{CC3}	-	-	15	30	
Stand-by Current(TTL)	I _{SB1}	CE#=V _{IH} , WP#=0V/V _{CC}	-	-	1	mA	
Stand-by Current(CMOS)	I _{SB2}	CE#=V _{CC} -0.2, WP#=0V/V _{CC}	-	10	50	mA	
Input Leakage Current	I _{LI}	V _{IN} =0 to V _{CC} (max)	-	-	±10	µA	
Output Leakage Current	I _{LO}	V _{OUT} =0 to V _{CC} (max)	-	-	±10		
Input High Voltage	V _{IH}	-	0.8xV _{CC}	-	V _{CC} +0.3	V	
Input Low Voltage, All inputs	V _{IL}	-	-0.3	-	0.2xV _{CC}		
Output High Voltage Level	V _{OH}	I _{OH} =-400µA	2.4	-	-		
Output Low Voltage Level	V _{OL}	I _{OL} =2.1mA	-	-	0.4		
Output Low Current(R/B)	I _{OL} (R/B#)	V _{OL} =0.4V	8	10	-	mA	

Note:

- V_{IL} can undershoot to -0.4V and V_{IH} can overshoot to V_{CC}+0.4V for durations of 20ns or less.
- Typical value are measured at V_{CC}=3.3V, TA=25°C. And not 100% tested.

VALID BLOCK

Parameter	Symbol	Min.	Typ.	Max.	Unit
A5U1GA31ABF/ A5U1GA31ATS/ A5U1GA41ATS	N _{VB}	1,004	-	1,024	Blocks

Note:

- The device may include initial invalid blocks when first shipped. Additional invalid blocks may develop while being used. The number of valid blocks is presented as first shipped. Invalid blocks are defined as blocks that contain one or more bad bits which cause status failure during program and erase operation. Do not erase or program factory-marked bad blocks. Refer to the attached technical notes for appropriate management of initial invalid blocks.
- The 1st block, which is placed on 00h block address, is guaranteed to be a valid block up to 1K program/erase cycles with 1 bit/528 bytes ECC.

AC TEST CONDITION

(Commercial: TA=0 to 70°C, Extended: TA=-25 to 85°C, Industrial: TA=-40 to 85°C, V_{CC}=2.7V~3.6V, unless otherwise noted)

Parameter	A5U1GA31ABF / A5U1GA31ATS / A5U1GA41ATS
Input Pulse Levels	0V to V _{CC}
Input Rise and Fall Times	5 ns
Input and Output Timing Levels	V _{CC} / 2
Output Load	1 TTL Gate and C _L =50pF

CAPACITANCE

(TA=25°C, V_{CC}=3.3V, f=1.0MHz)

Item	Symbol	Test Condition	Min.	Max.	Unit
Input/ Output Capacitance	C _{IO}	V _{IL} =0V	-	8	pF
Input Capacitance	C _{IN}	V _{IN} =0V	-	8	pF

Note:

- Capacitance is periodically sampled and not 100% tested.

MODE SELECTION

CLE	ALE	CE#	WE#	RE#	WP#	Mode	
H	L	L	Rising	H	X	Read Mode	Command Input
L	H	L	Rising	H	X		Address Input (4 clock)
H	L	L	Rising	H	H	Write Mode	Command Input
L	H	L	Rising	H	H		Address Input (4 clock)
L	L	L	Rising	H	H	Data Input	
L	L	L	H	Falling	X	Data Output	
X	X	X	X	H	X	During Read (Busy)	
X	X	X	X	X	H	During Program (Busy)	
X	X	X	X	X	H	During Erase (Busy)	
X	X ⁽¹⁾	X	X	X	L	Write Protect	
X	X	H	X	X	0V/V _{CC} ⁽²⁾	Stand-by	

Note:

- X can be V_{IL} or V_{IH}.
- WP# should be biased to CMOS high or CMOS low for stand-by.

Program / Erase Characteristics

Parameter	Symbol	Min.	Typ.	Max.	Unit
Program Time	t _{PROG} ⁽¹⁾	-	200	700	us
Dummy Busy Time for Cache Program	t _{CBSY} ⁽²⁾	-	3	700	us
Number of Partial Program Cycles in the Same Page	N _{OP}	-	-	4	cycle
Block Erase Time	t _{BERS}	-	1.5	10	ms

Note:

- Typical program time is defined as the time within which more than 50% of the whole pages are programmed at 3.3V V_{CC} and 25°C temperature.
- Max. time of t_{CBSY} depends on timing between internal program completion and data in.

AC Timing Characteristics for Command / Address / Data Input

Parameter	Symbol	Min.	Max.	Unit
CLE Setup Time	$t_{CLS}^{(1)}$	12	-	ns
CLE Hold Time	t_{CLH}	5	-	ns
CE# Setup Time	t_{CS}	20	-	ns
CE# Hold Time	t_{CH}	5	-	ns
WE# Pulse Width	t_{WP}	12	-	ns
ALE Setup Time	$t_{ALS}^{(1)}$	12	-	ns
ALE Hold Time	t_{ALH}	5	-	ns
Data Setup Time	$t_{DS}^{(1)}$	12	-	ns
Data Hold Time	t_{DH}	5	-	ns
Write Cycle Time	t_{WC}	25	-	ns
WE# High Hold Time	t_{WH}	10	-	ns
ALE to Data Loading Time	$t_{ADL}^{(2)}$	100	-	ns

Note:

1. The transition of the corresponding control pins must occur only once while WE# is held low.
2. t_{ADL} is the time from the WE# rising edge of final address cycle to the WE# rising edge of first data cycle.

AC Characteristics for Operation

Parameter	Symbol	Min.	Max.	Unit	
Data Transfer from Cell to Register	t_R	-	25	us	
ALE to RE# Delay	t_{AR}	10	-	ns	
CLE to RE# Delay	t_{CLR}	10	-	ns	
Ready to RE# Low	t_{RR}	20	-	ns	
RE# Pulse Width	t_{RP}	12	-	ns	
WE# High to Busy	t_{WB}	-	100	ns	
Read Cycle Time	t_{RC}	25	-	ns	
RE# Access Time	t_{REA}	-	20	ns	
CE# Access Time	t_{CEA}	-	25	ns	
RE# High to Output Hi-Z	t_{RHZ}	-	100	ns	
CE# High to Output Hi-Z	t_{CHZ}	-	30	ns	
CE# High to ALE or CLE Don't Care	t_{CSD}	0	-	ns	
RE# High to Output Hold	t_{RHOH}	15	-	ns	
RE# Low to Output Hold	t_{RLOH}	5	-	ns	
CE# High to Output Hold	t_{COH}	15	-	ns	
RE# High Hold Time	t_{REH}	10	-	ns	
Output Hi-Z to RE# Low	t_{IR}	0	-	ns	
RE# High to WE# Low	t_{RHW}	100	-	ns	
WE# High to RE# Low	t_{WHR}	60	-	ns	
Device Resetting Time during ...	Read	t_{RST}	-	5 ⁽¹⁾	us
	Program		-	10 ⁽¹⁾	us
	Erase		-	500 ⁽¹⁾	us
	Ready		-	5 ⁽¹⁾	us

Note:

1. If reset command (FFh) is written at Ready state, the device goes into Busy for maximum 5us.

NAND Flash Technical Notes

Initial Invalid Block(s)

Initial invalid blocks are defined as blocks that contain one or more initial invalid bits whose reliability is not guaranteed. Information regarding the initial invalid block(s) is so called as the initial invalid block information. Devices with initial invalid block(s) have the same quality level as devices with all valid blocks and have the same AC and DC characteristics. An initial invalid block(s) does not affect the performance of valid block(s) because it is isolated from the bit line and the common source line by a select transistor. The system design must be able to mask out the initial invalid block(s) via address mapping.

The 1st block, which is placed on 00h block address, is guaranteed to be a valid block up to 1K program/erase cycles with 1 bit/528 bytes ECC.

Identifying Initial Invalid Block(s)

All device locations are erased (FFh) except locations where the initial invalid block(s) information is written prior to shipping. The initial invalid block(s) status is defined by the 1st byte(x8) or 1st word(x16) in the spare area; either the 1st or 2nd page of every initial invalid block has non-FFh data at the 1st byte(x8) or 1st word(x16) column address in the spare area. Since the initial invalid block information is also erasable in most cases, it is impossible to recover the information once it has been erased. Therefore, the system must be able to recognize the initial invalid block(s) based on the initial invalid block information and create the initial invalid block table via the following suggested flow chart. Any intentional erasure of the initial invalid block information is prohibited.

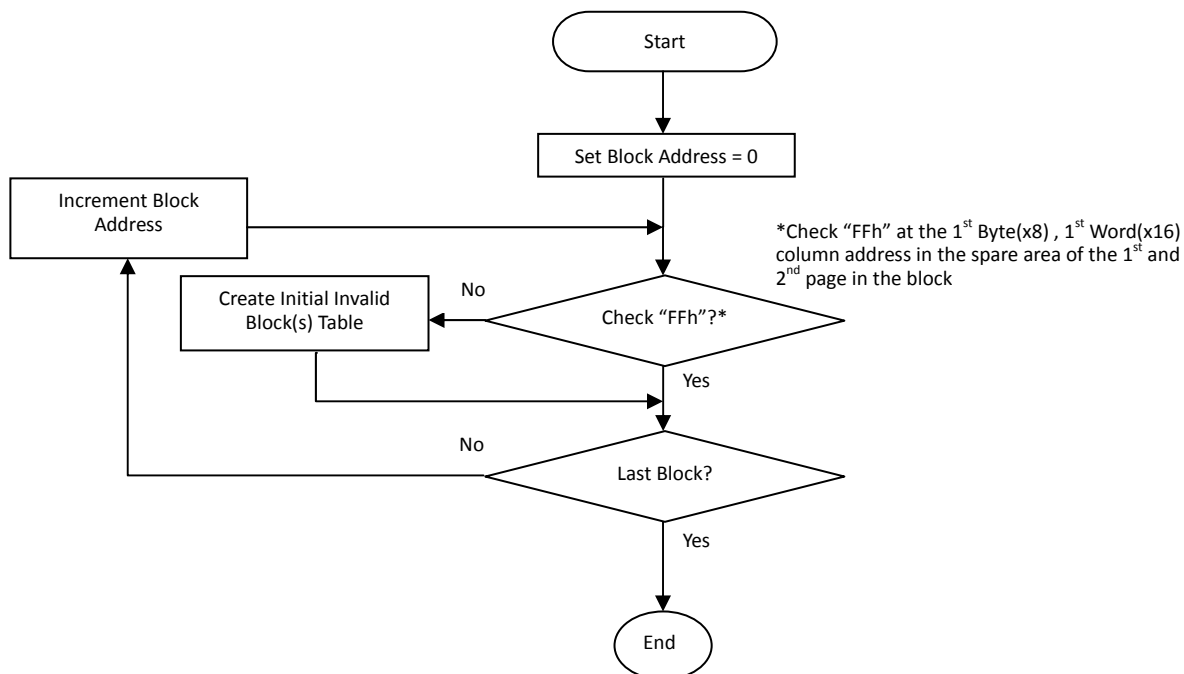

Error in write or read operation

Within its life time, the additional invalid blocks may develop with NAND Flash memory. Refer to the qualification report for the block failure rate. The following possible failure modes should be considered to implement a highly reliable system. In the case of status read failure after erase or program, block replacement should be done. Because program status fail during a page program does not affect the data of the other pages in the same block, block replacement can be executed with a page-sized buffer by finding an erased empty block and reprogramming the current target data and copying the rest of the replaced block. In case of Read, ECC must be employed. To improve the efficiency of memory space, it is recommended that the read failure due to single bit error should be reclaimed by ECC without any block replacement. The block failure rate in the qualification report does not include those reclaimed blocks.

Failure		Detection and Countermeasure sequence
Write	Erase Failure	Status Read after Erase → Block Replacement
	Program Failure	Status Read after Program → Block Replacement
Read	Single Bit Failure	Verify ECC → ECC Correction

ECC:

1. Error Correcting Code --> Hamming Code etc.
2. Example) 1bit correction & 2bits detection

Program Flow Chart

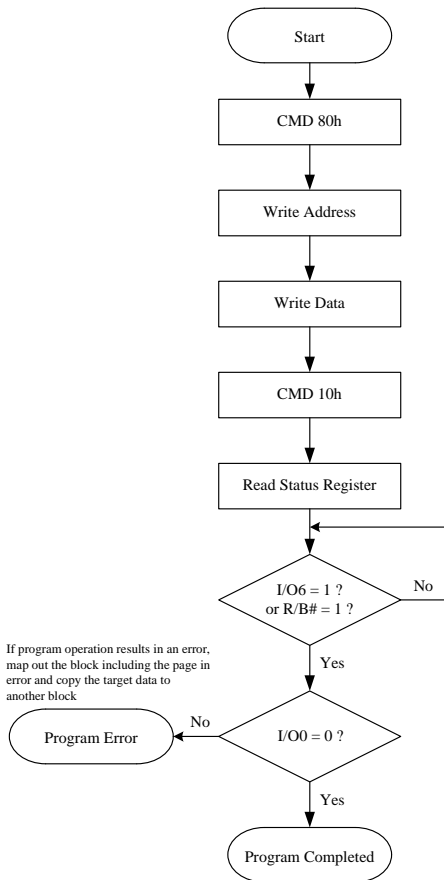

Erase Flow Chart

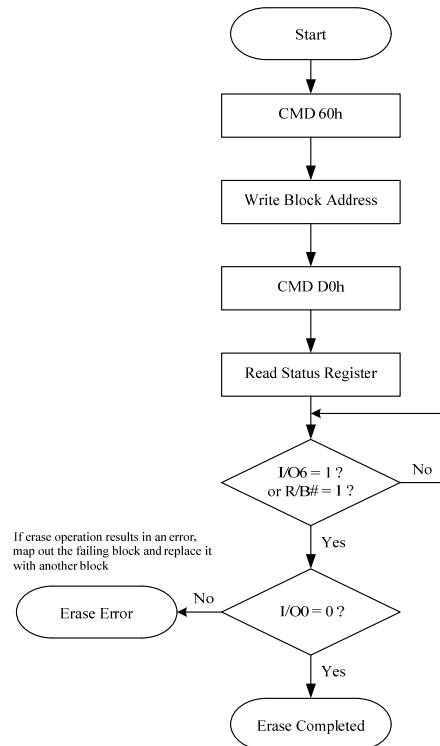

Read Flow Chart

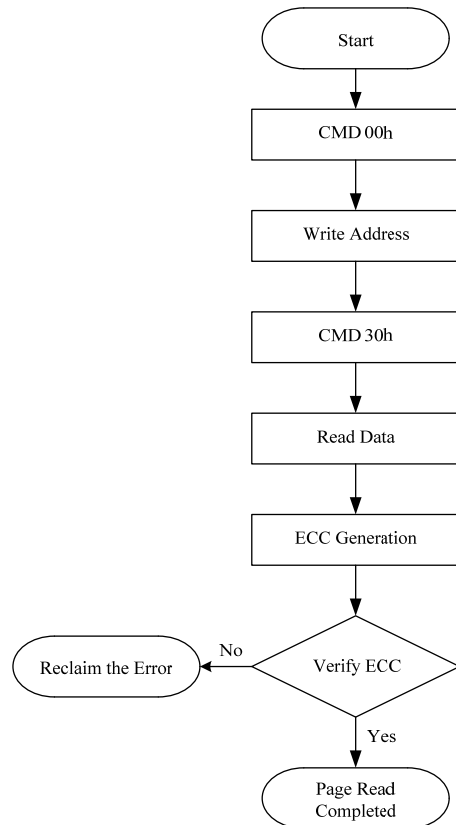

Block Replacement

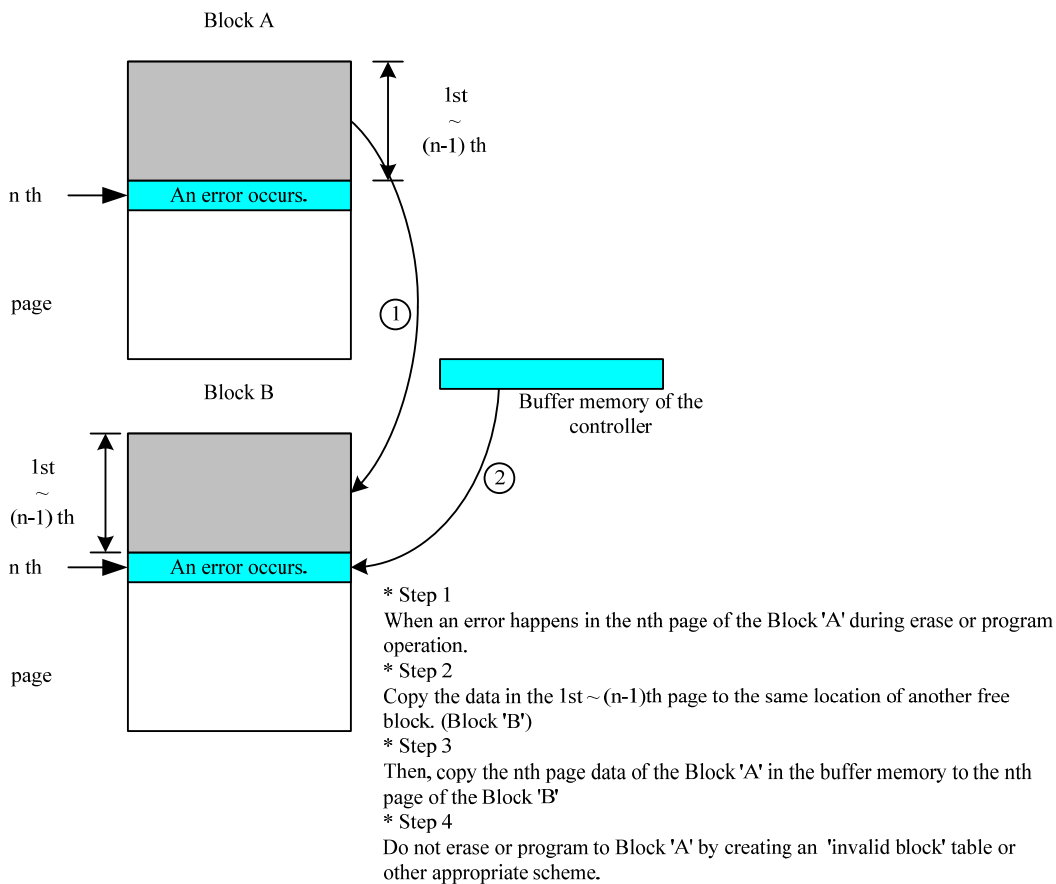

Addressing for program operation

Within a block, the pages must be programmed consecutively from the LSB (Least Significant Bit) page of the block to MSB (Most Significant Bit) pages of the block. Random page address programming is prohibited.

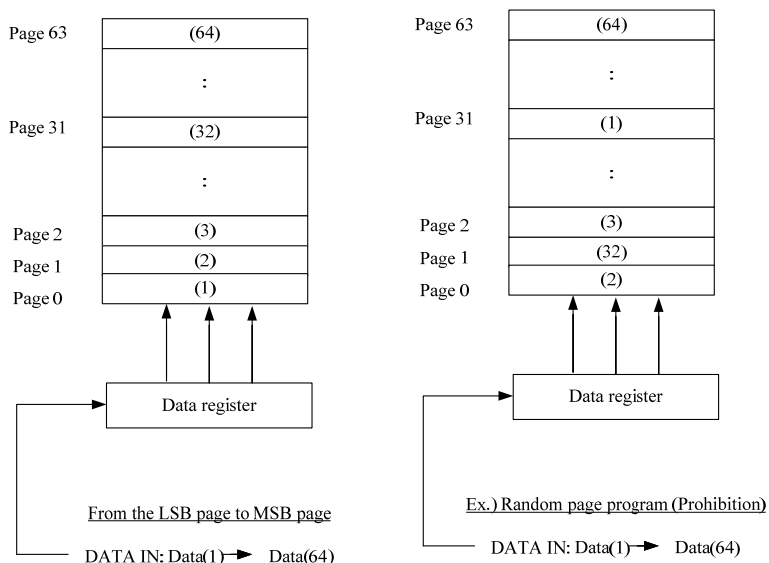

System Interface Using CE# don't-care

For an easier system interface, CE# may be inactive during the data-loading or sequential data-reading as shown below. The internal 2,112 bytes(x8) or 1,056 words(x16) page registers are utilized as separate buffers for this operation and the system design gets more flexible. In addition, for voice or audio applications which use slow cycle time on the order of u-seconds, de-activating CE# during the data-loading and reading would provide significant savings in power consumption. Below are the figures of Program Operation and Read Operation with CE# don't-care respectively.

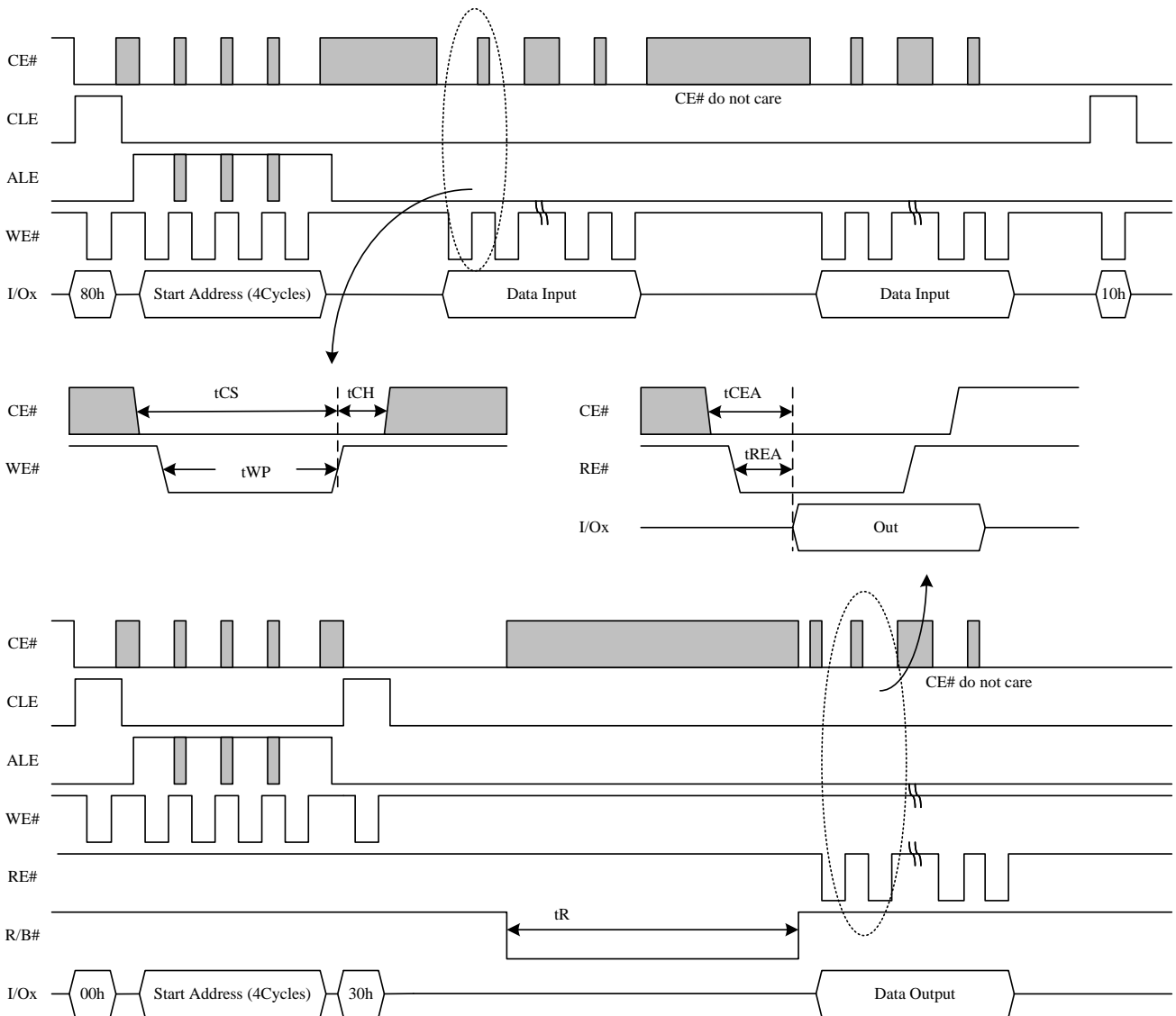

Address Information

Parameter	I/O	DATA	ADDRESS			
	I/Ox	Data In/Out	Col. Add1	Col. Add2	Row Add1	Row Add2
A5U1GA31ABF A5U1GA31ATS	I/O0~7	~ 2112 bytes	A ₀ ~ A ₇	A ₈ ~ A ₁₁	A ₁₂ ~ A ₁₉	A ₂₀ ~ A ₂₇
A5U1GA41ATS	I/O0~15	~ 1056 words	A ₀ ~ A ₇	A ₈ ~ A ₁₀	A ₁₁ ~ A ₁₈	A ₁₉ ~ A ₂₆

Command Latch Cycle

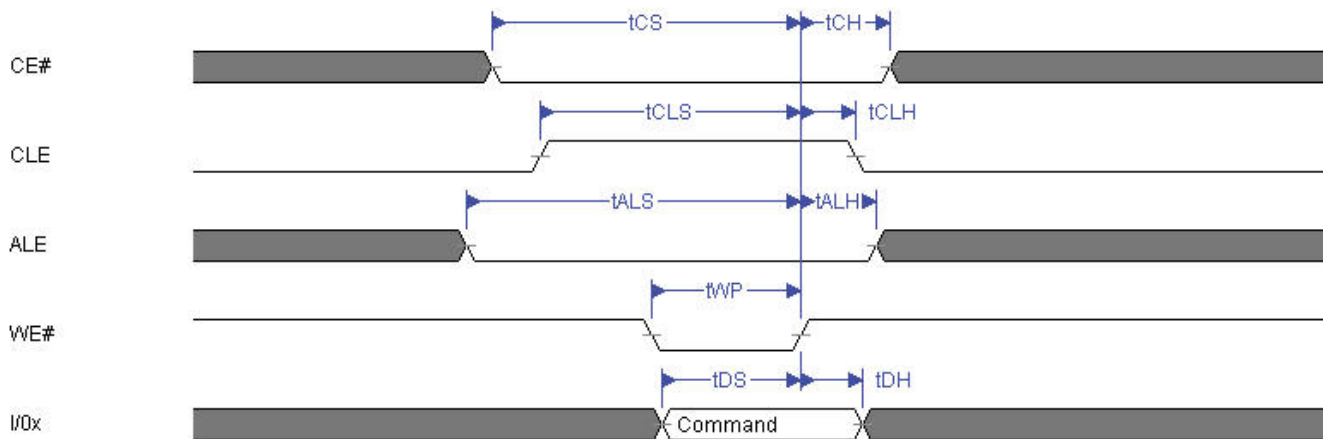

Address Latch Cycle

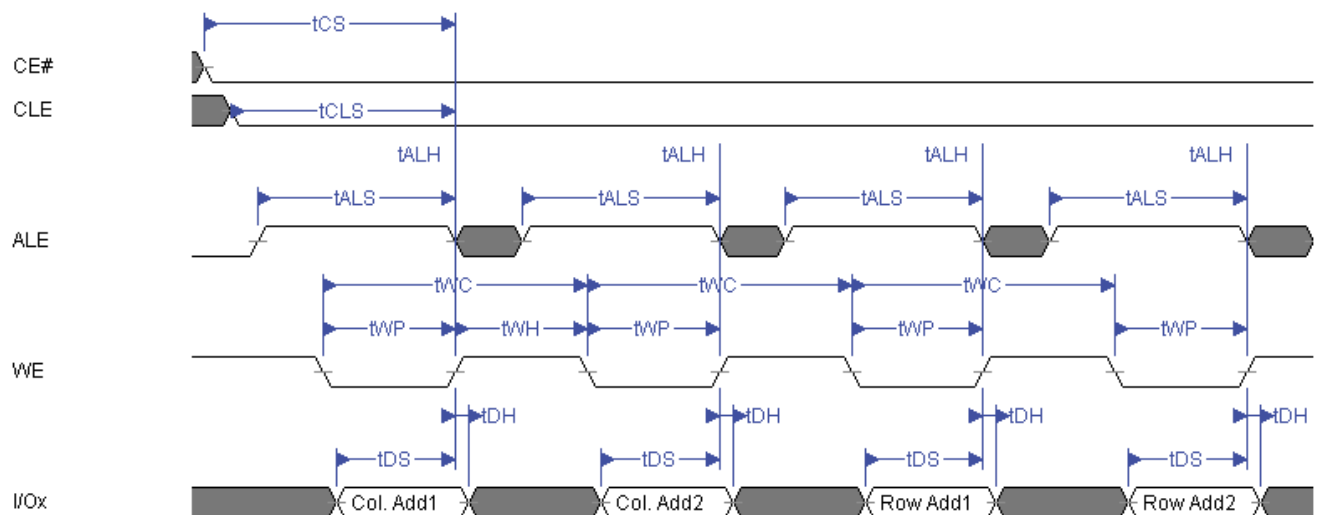

Input Data Latch Cycle

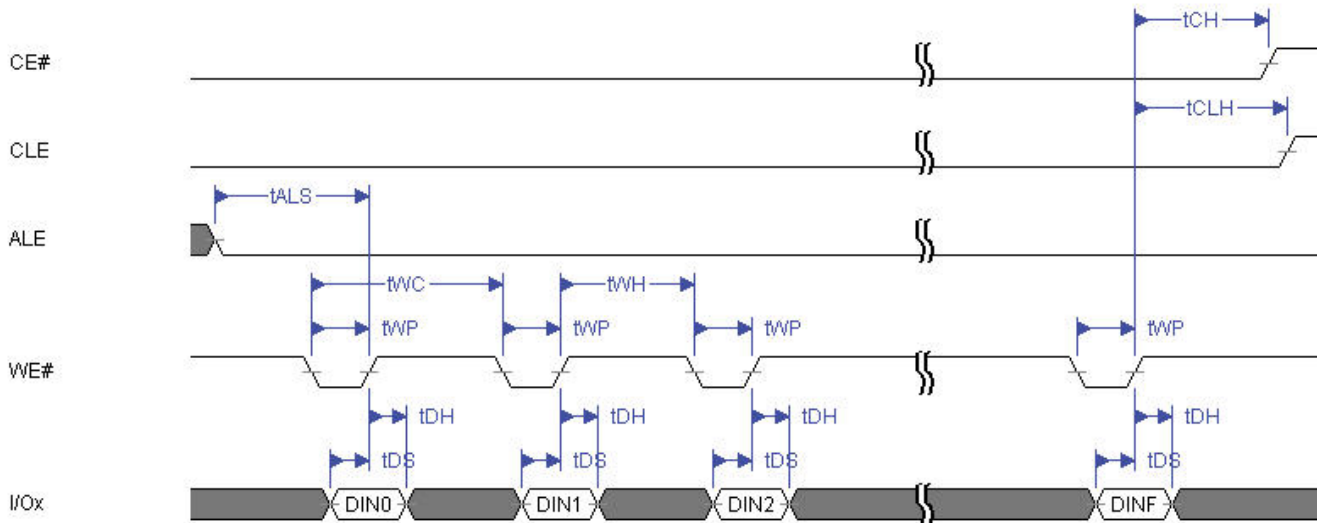

Serial access Cycle after Read (CLE=L, ALE=L, WE#=H)

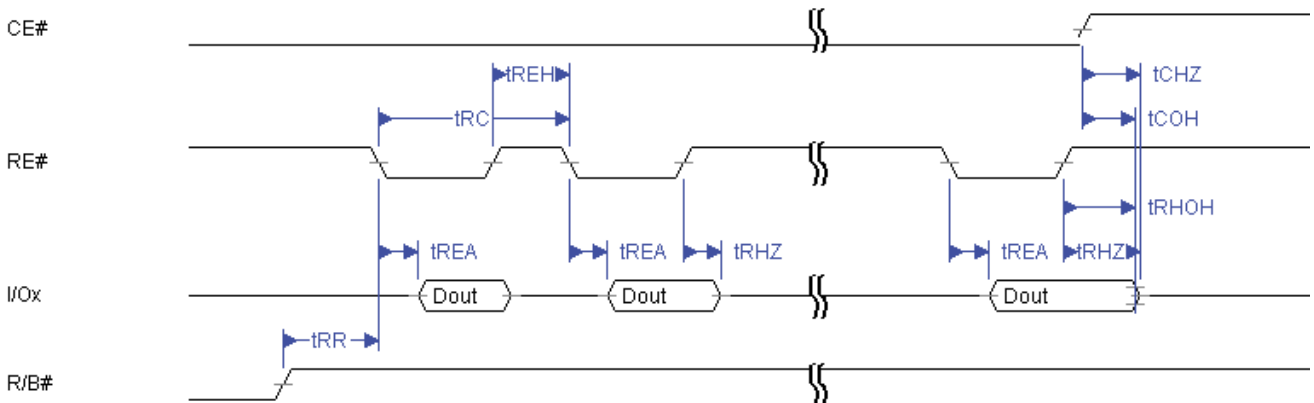

Note:

1. Transition is measured at $\pm 200\text{mV}$ from steady state voltage with load.
2. This parameter is sampled and not 100% tested.
3. t_{RLOH} is valid when frequency is higher than 33MHz.
4. t_{RHOH} starts to be valid when frequency is lower than 33MHz.

Status Read Cycle

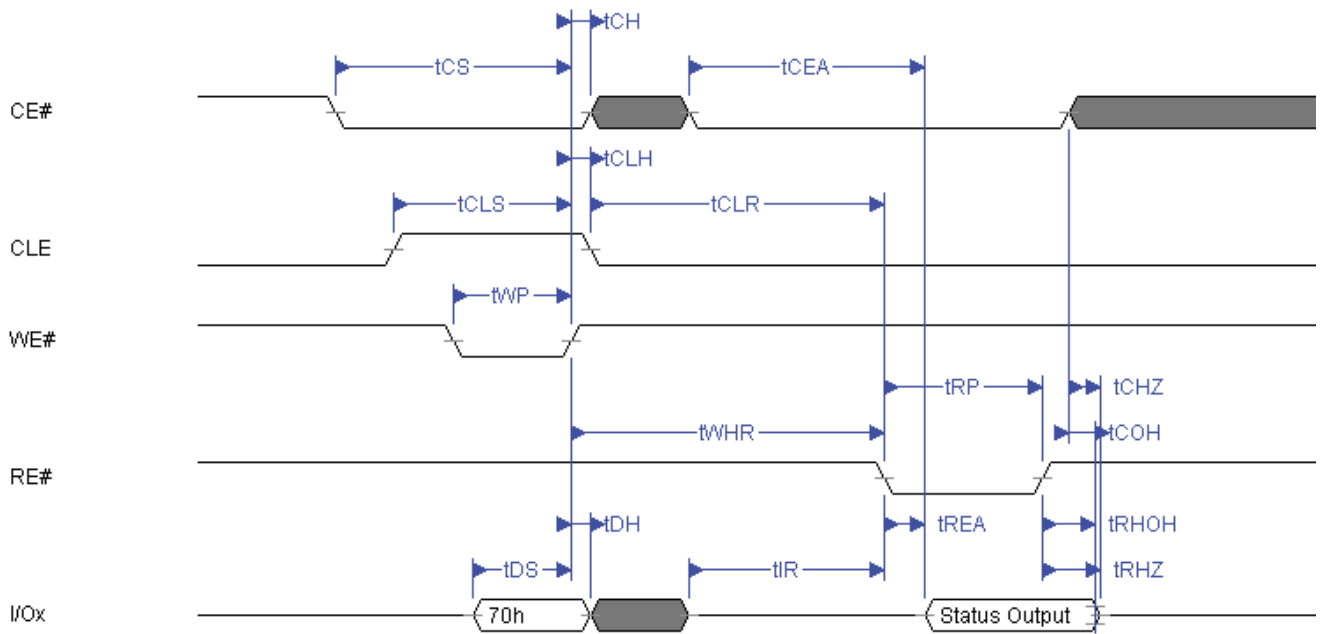

READ Operation

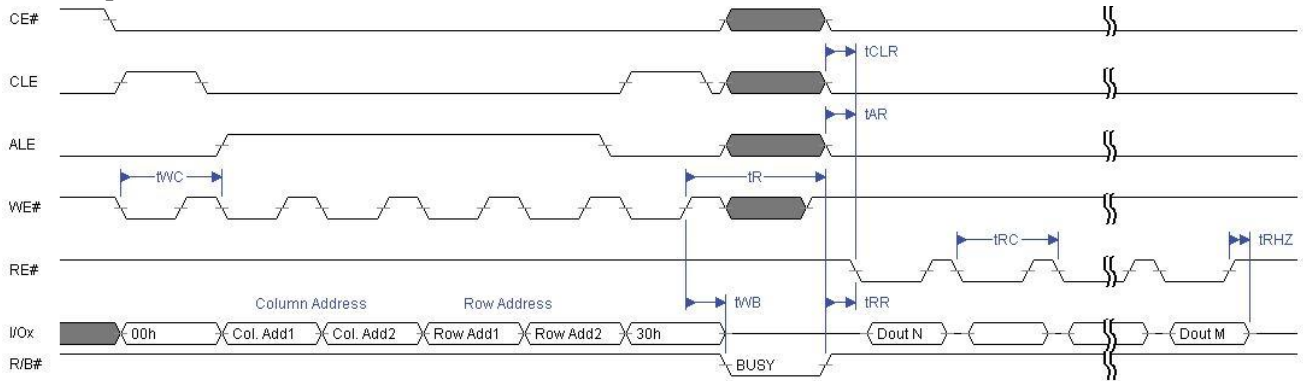

READ Operation (Intercepted by CE#)

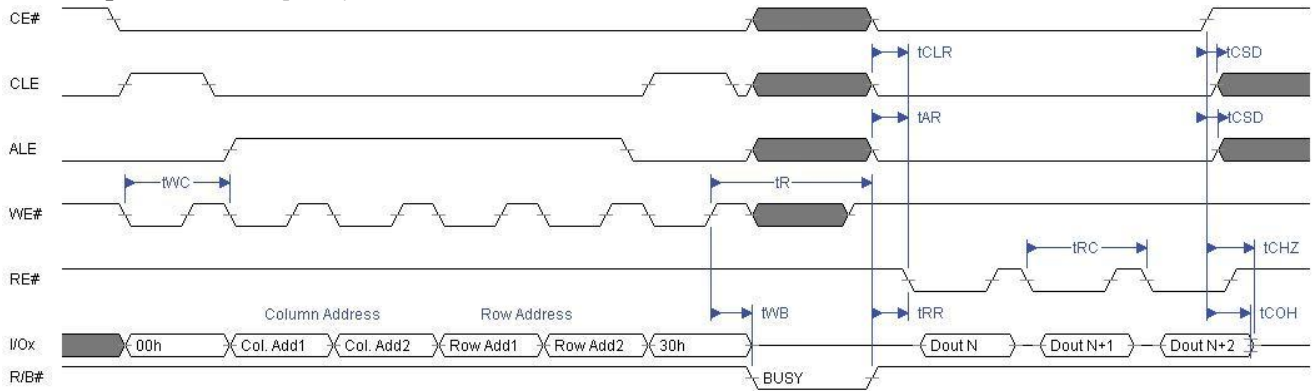

Random Data Output In a Page

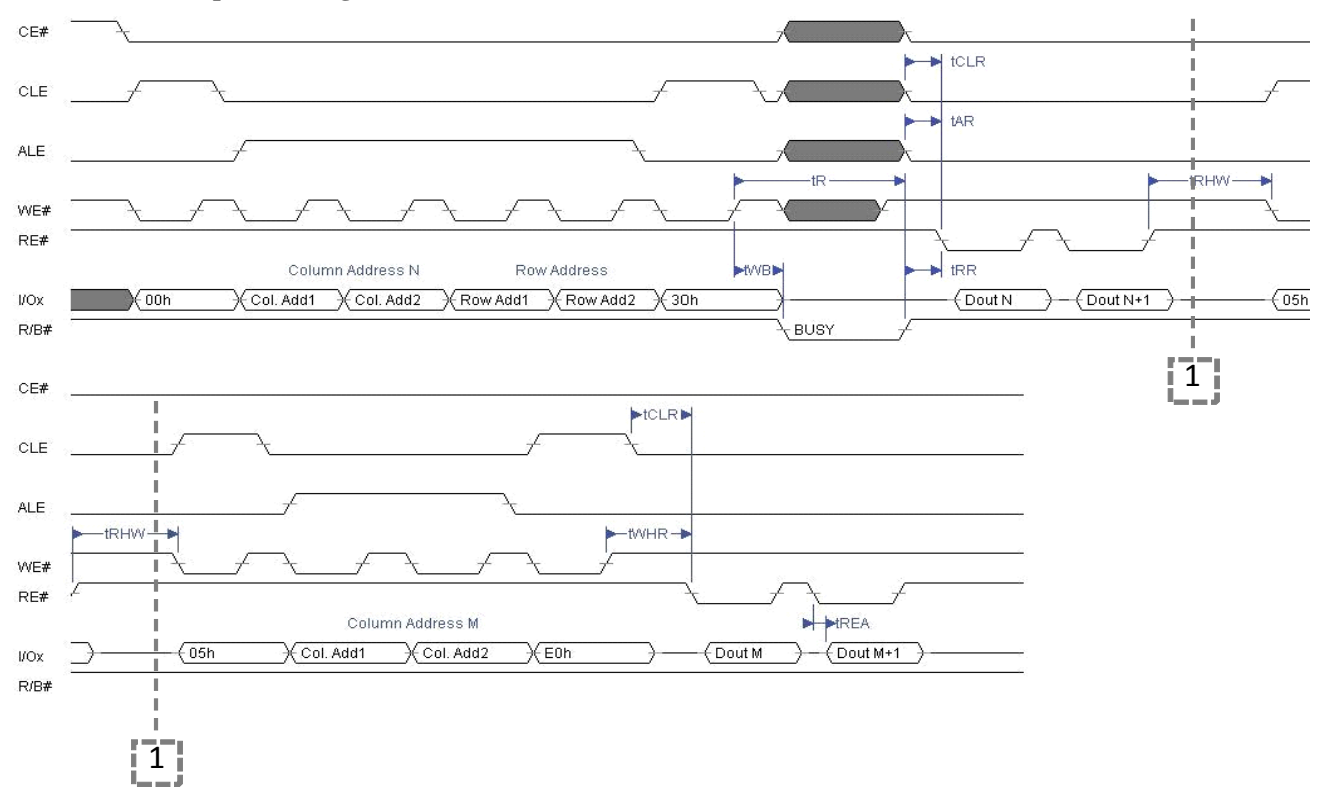

Page Program Operation

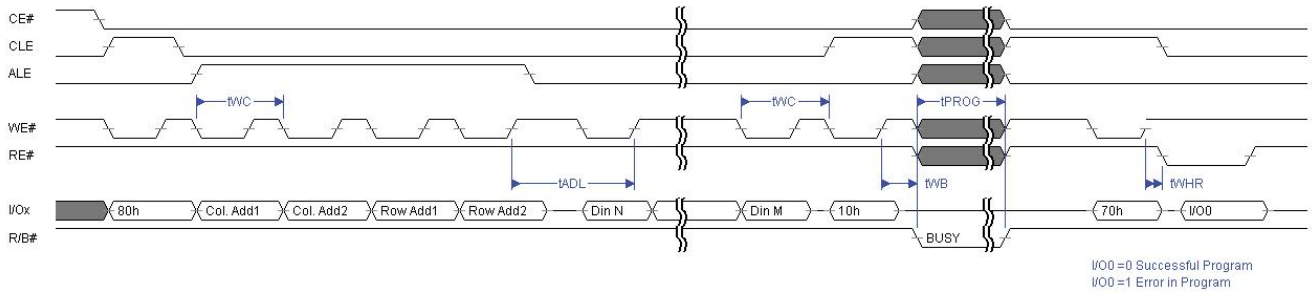

Notes:

1. t_{ADL} is the time from WE# rising edge of final address cycle to the WE# rising edge of first data cycle.

Page Program Operation with Random Data Input

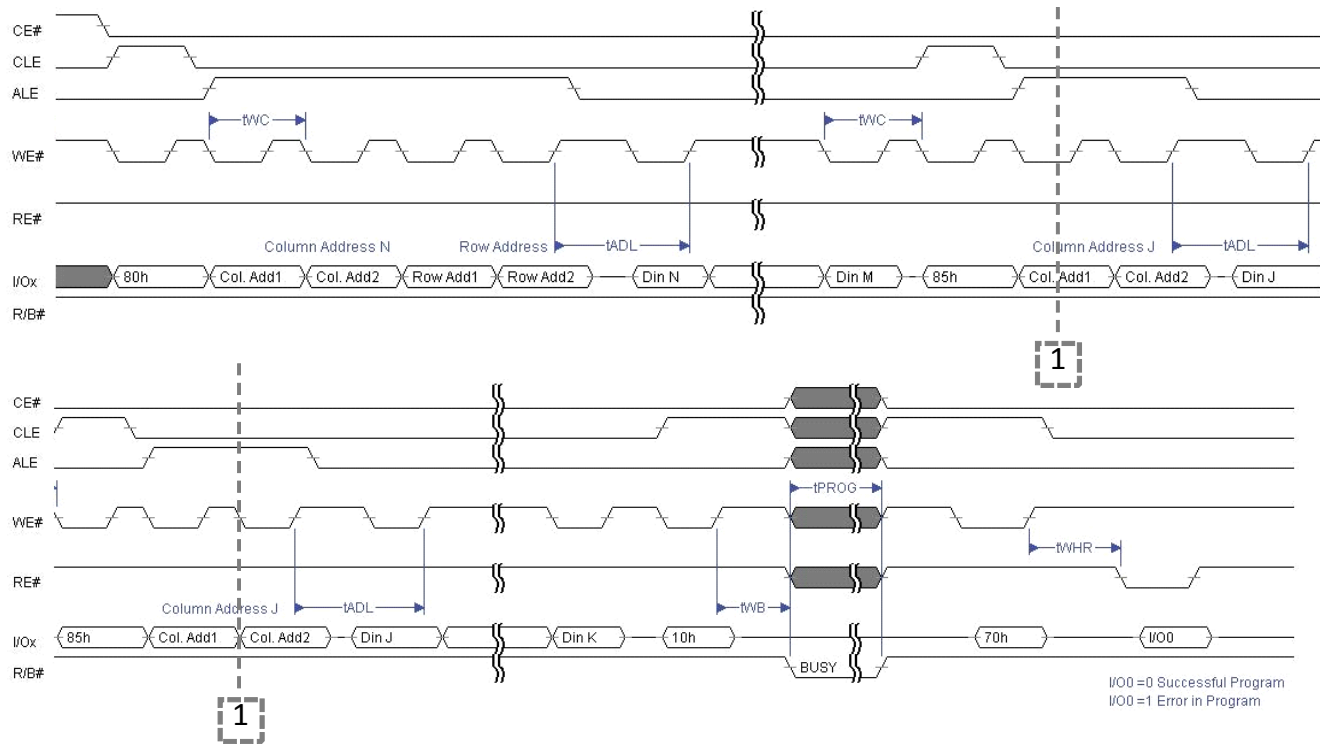

Notes:

1. t_{ADL} is the time from WE# rising edge of final address cycle to the WE# rising edge of first data cycle.

Copy-Back Program Operation with Random Data Input

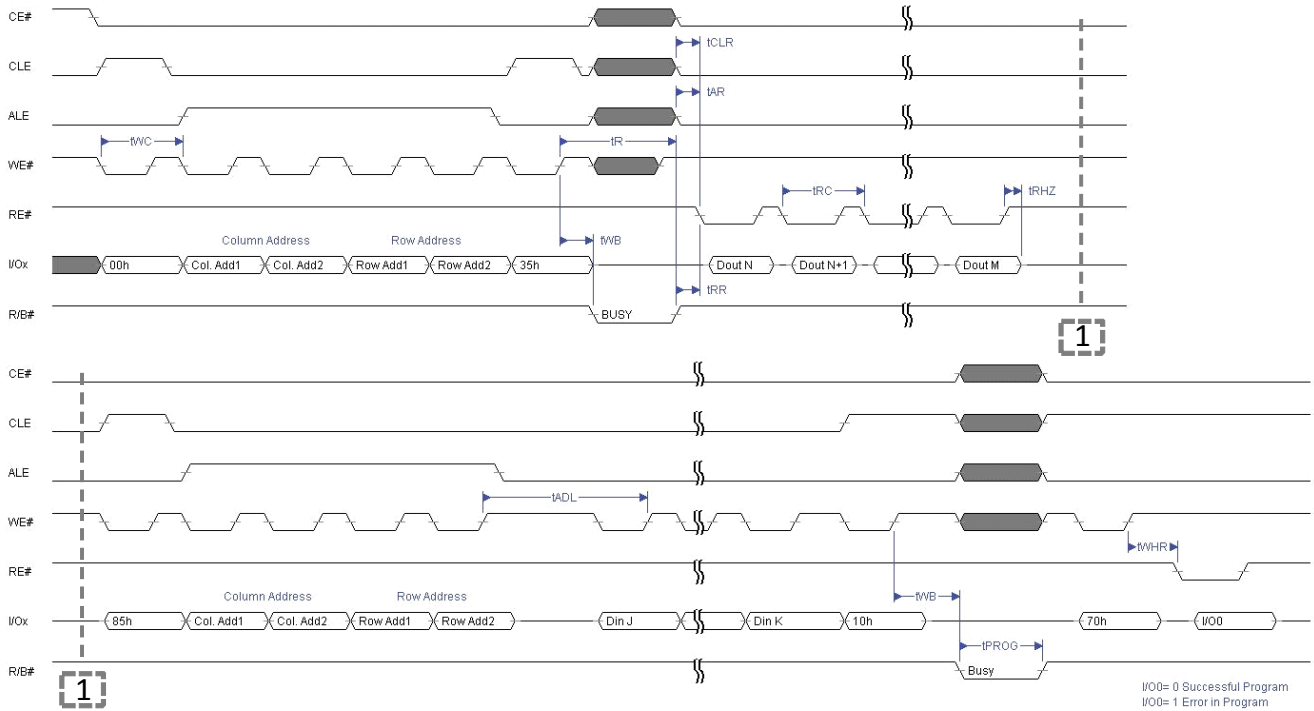

Notes:

1. t_{ADL} is the time from WE# rising edge of final address cycle to the WE# rising edge of first data cycle.

Cache Program Operation (available only within a block)

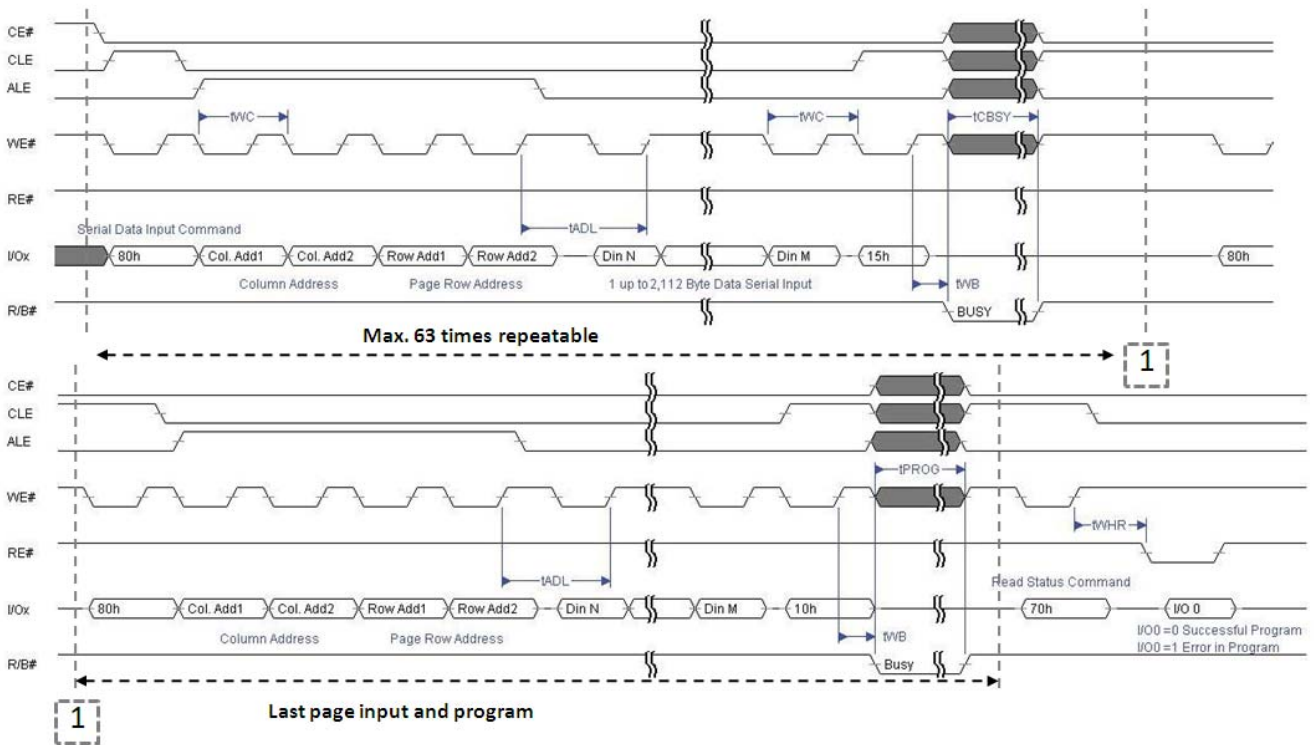

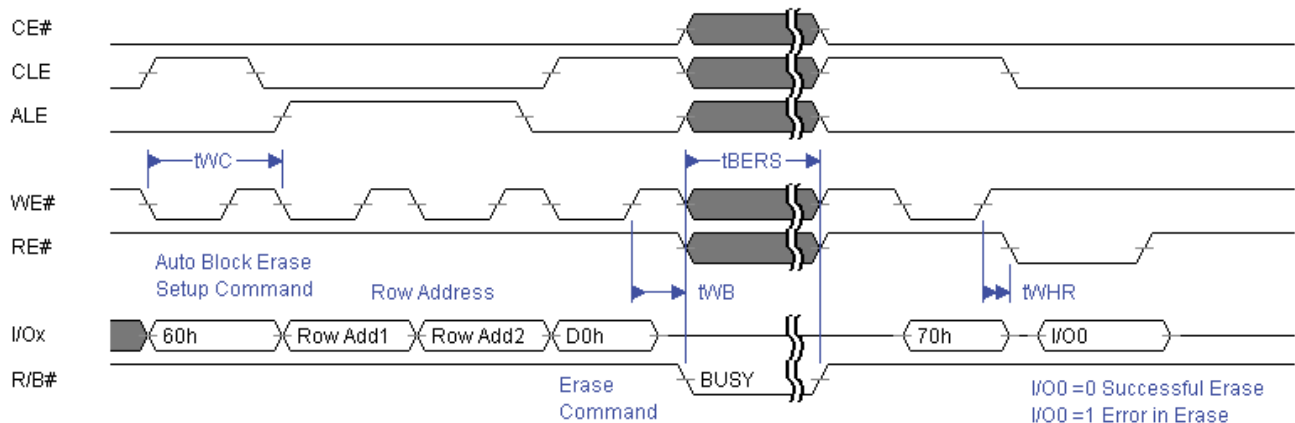
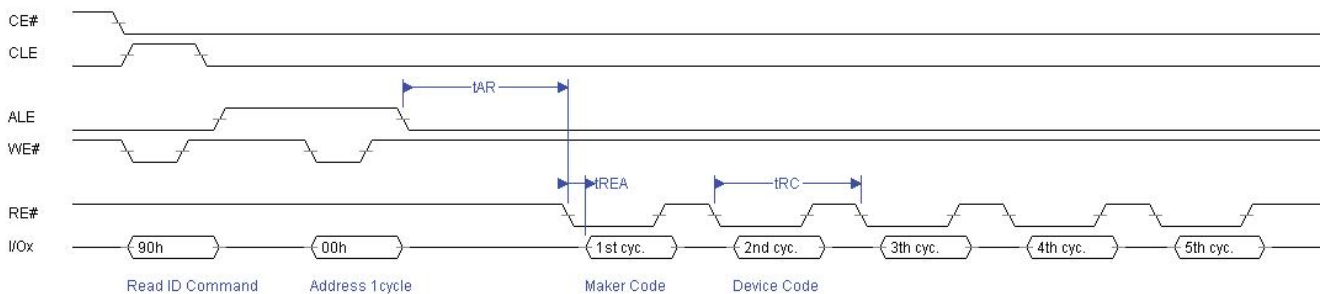
Block Erase Operation (Erase One Block)

Read ID Operation

ID Definition Table

ID Access command = 90h

Option	Maker Code	Device Code	3 rd Cycle	4 th Cycle	5 th Cycle	Note
x8	92h	F1h	80h	95h	40h	
x16	92h	C1h	80h	D5h	40h	

	Description
1 st Byte	Maker Code
2 nd Byte	Device Code
3 rd Byte	Internal Chip Number, Cell Type, Number of Simultaneously Programmed Pages, Etc.
4 th Byte	Page Size, Block Size, Redundant Area Size, Organization, Serial Access Minimum
5 th Byte	Plane Number, Plane Size



A5U1GA31ABF
A5U1GA31ATS/A5U1GA41ATS
 128M x 8bit / 64M x 16bit NAND Flash Memory

3rd ID Data

	Description	I/O7	I/O6	I/O5	I/O4	I/O3	I/O2	I/O1	I/O0
Internal Chip Number	1							0	0
	2							0	1
	4							1	0
	8							1	1
Cell Type	2 Level Cell					0	0		
	4 Level Cell					0	1		
	8 Level Cell					1	0		
	16 Level Cell					1	1		
Number of Simultaneously Programmed Page	1			0	0				
	2			0	1				
	4			1	0				
	8			1	1				
Interleave Program Between multiple chips	Not Support Support		0 1						
Cache Program	Not Support Support	0 1							

4th ID Data

	Description	I/O7	I/O6	I/O5	I/O4	I/O3	I/O2	I/O1	I/O0
Page Size (w/o redundant area)	1KB							0	0
	2KB							0	1
	4KB							1	0
	8KB							1	1
Block Size (w/o redundant area)	64KB			0	0				
	128KB			0	1				
	256KB			1	0				
	512KB			1	1				
Redundant Area Size (byte/512byte)	8						0		
	16						1		
Organization	x8		0						
	x16		1						
Serial Access Minimum	50ns/30ns	0				0			
	25ns	1				0			
	Reserved	0				1			
	Reserved	1				1			

5th ID Data

	Description	I/O7	I/O6	I/O5	I/O4	I/O3	I/O2	I/O1	I/O0
Plane Number	1					0	0		
	2					0	1		
	4					1	0		
	8					1	1		
Plane Size (w/o redundant Area)	64Mb		0	0	0				
	128Mb		0	0	1				
	256Mb		0	1	0				
	512Mb		0	1	1				
	1Gb		1	0	0				
	2Gb		1	0	1				
	4Gb		1	1	0				
8Gb		1	1	1					
Reserved		0						0	0

DEVICE OPERATION

Page Read

Page read is initiated by writing 00h-30h to the command register along with four address cycles. After initial power up, 00h command is latched. Therefore only four address cycles and 30h command initiates that operation after initial power up. The 2,112 bytes(x8) or 1,056 words(x16) of data within the selected page are transferred to the data registers in less than t_R . The system controller can detect the completion of this data transfer (t_R) by analyzing the output of R/B# pin. Once the data in a page is loaded into the data registers, they may be read out in 25ns cycle time by sequentially pulsing RE#. The repetitive high to low transitions of the RE# clock make the device output the data starting from the selected column address up to the last column address.

The device may output random data in a page instead of the consecutive sequential data by writing random data output command. The column address of next data, which is going to be out, may be changed to the address which follows random data output command. Random data output can be operated multiple times regardless of how many times it is done in a page.

Read Operation

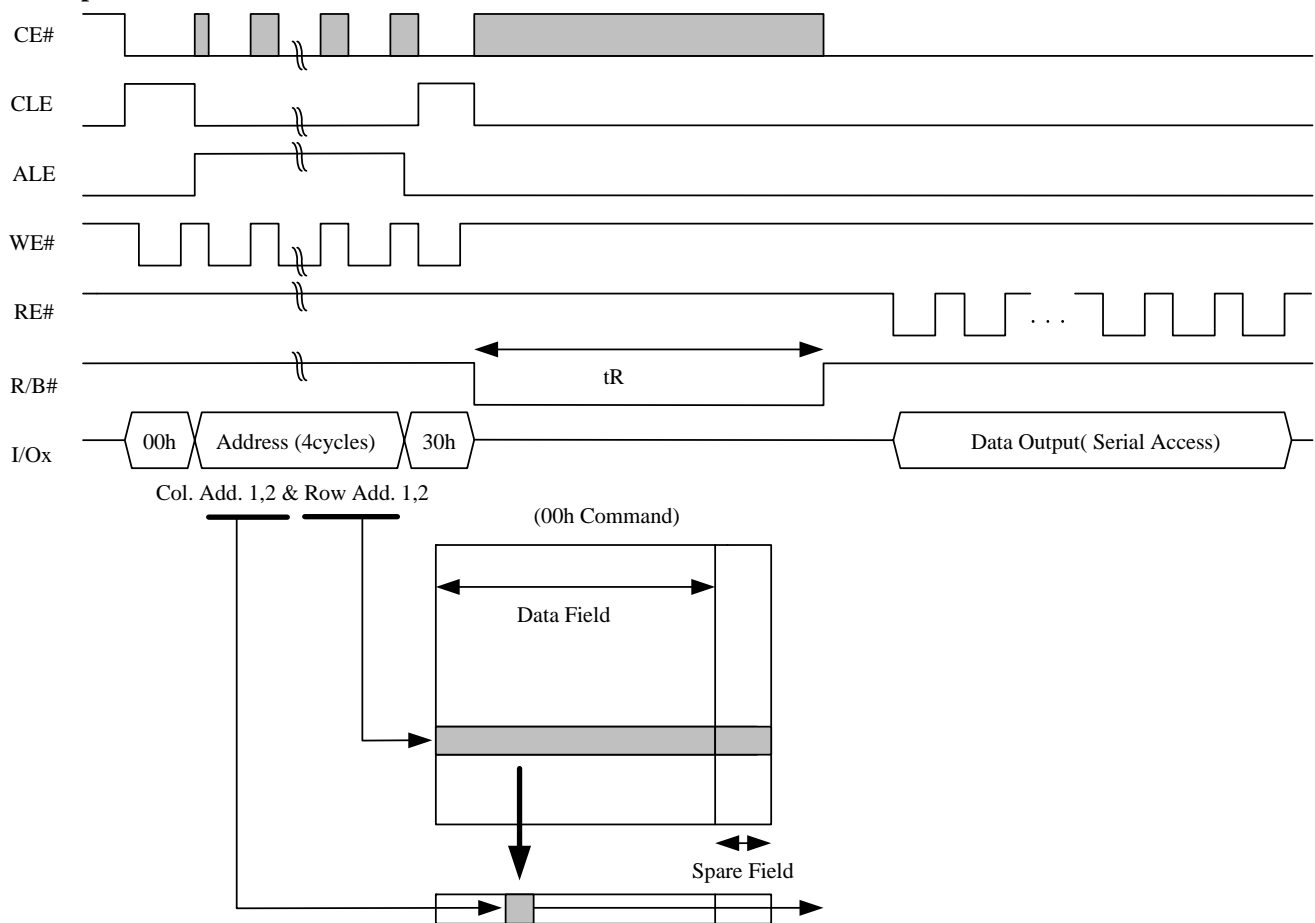

Random Data Output In a Page

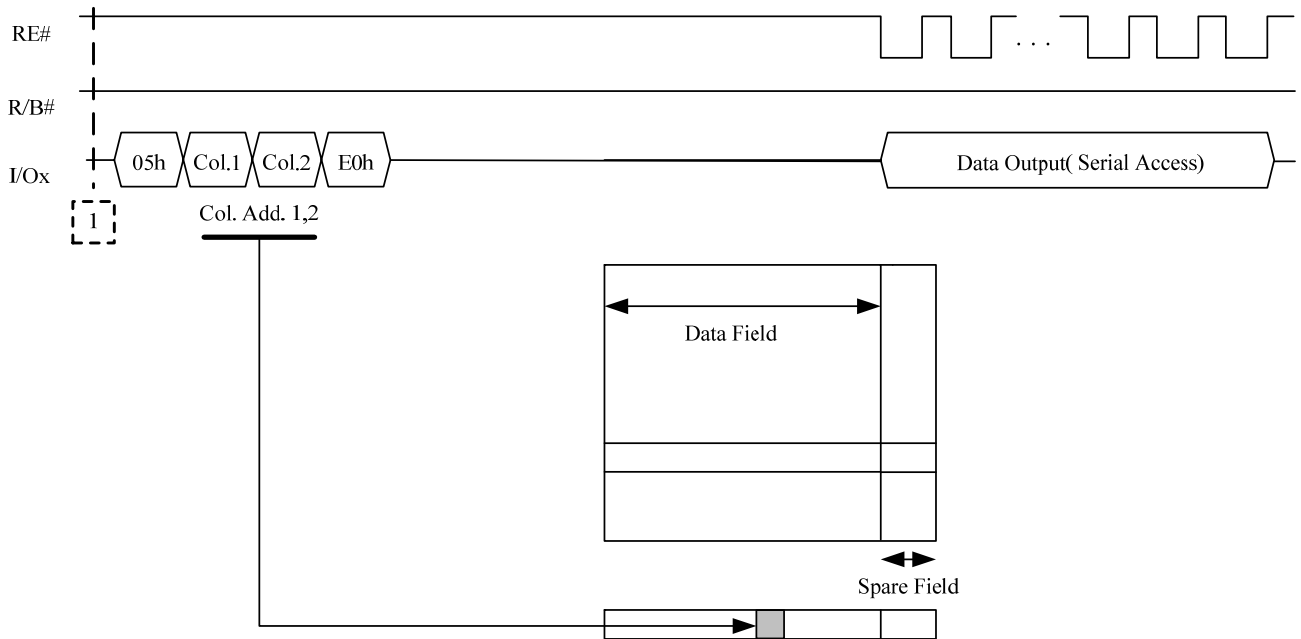
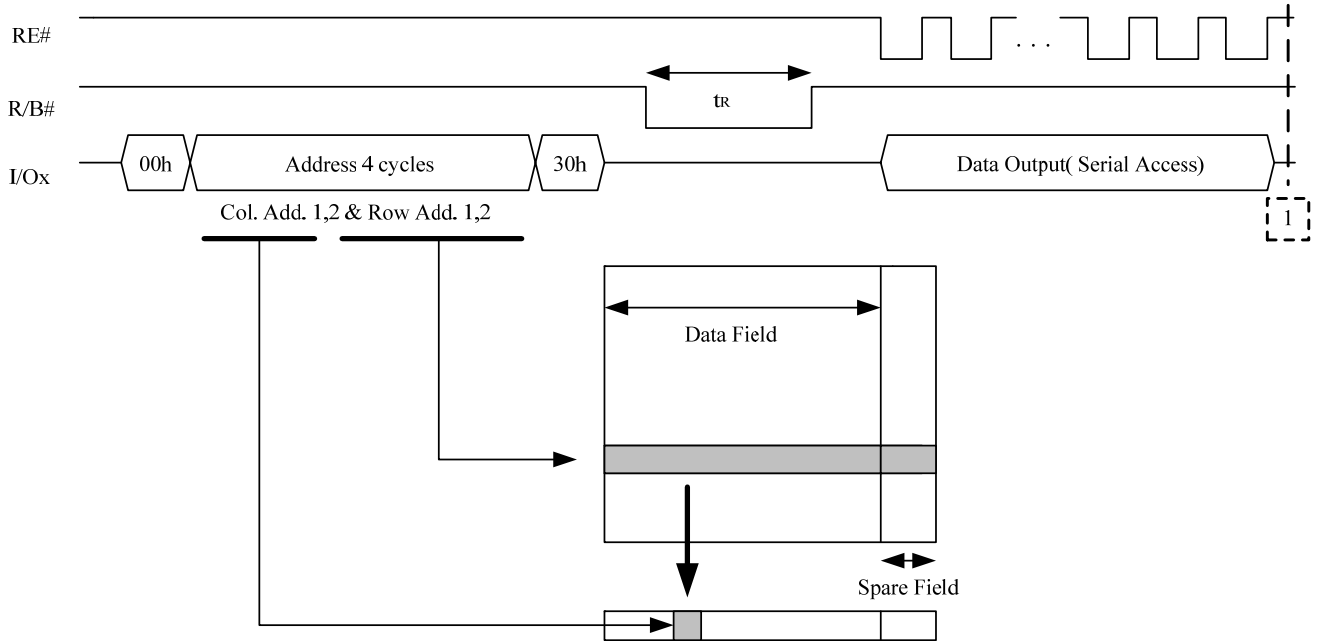

Page Program

The device is programmed basically on a page basis, but it does allow multiple partial page programming of a word or consecutive bytes up to 2,112(x8) or words up to 1,056(x16), in a single page program cycle. The number of consecutive partial page programming operation within the same page without an intervening erase operation must not exceed 4 times for a single page. The addressing should be done in sequential order in a block. A page program cycle consists of a serial data loading period in which up to 2,112 bytes(x8) or 1,056 words(x16) of data may be loaded into the data register, followed by a non-volatile programming period where the loaded data is programmed into the appropriate cell.

The serial data loading period begins by inputting the Serial Data Input command (80h), followed by the four cycle address inputs and then serial data loading. The words other than those to be programmed do not need to be loaded. The device supports random data input in a page. The column address for the next data, which will be entered, may be changed to the address which follows random data input command (85h). Random data input may be operated multiple times regardless of how many times it is done in a page.

The Page Program confirm command (10h) initiates the programming process. Writing 10h alone without previously entering the serial data will not initiate the programming process. The internal write state controller automatically executes the algorithms and timings necessary for program and verify, thereby freeing the system controller for other tasks. Once the program process starts, the Read Status Register command may be entered, with RE# and CE# low, to read the status register. The system controller can detect the completion of a program cycle by monitoring the R/B output, or the Status bit (I/O6) of the Status Register. Only the Read Status command and Reset command are valid while programming is in progress. When the Page Program is complete, the Write Status Bit (I/O0) may be checked. The internal write verify detects only errors for "1"s that are not successfully programmed to "0"s. The command register remains in Read Status command mode until another valid command is written to the command register.

Program & Read Status Operation

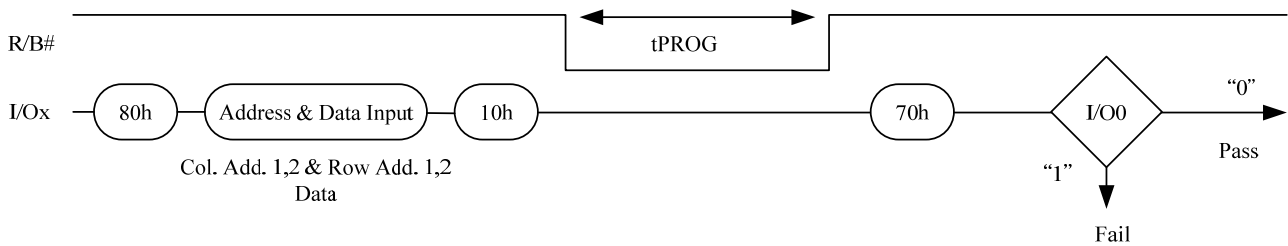

Random Data Input In a page

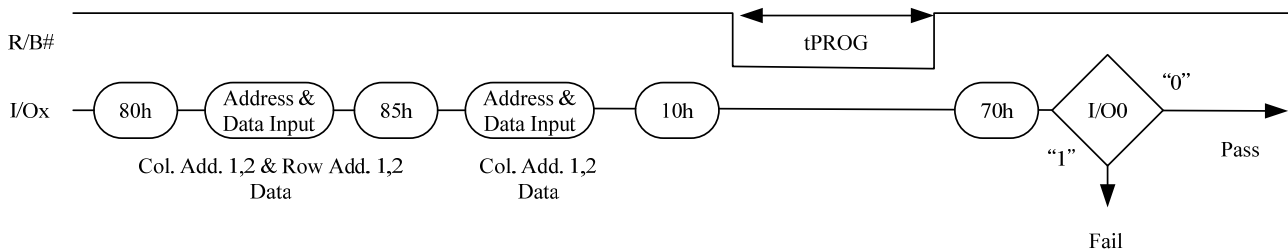

Cache Program

Cache Program is an extension of Page Program, which is executed with 2,112 byte(x8) or 1,056 words(x16) data registers, and is available only within a block. Since the device has 1 page of cache memory, serial data input may be executed while data stored in data register are programmed into memory cell.

After writing the first set of data up to 2,112 bytes(x8) or 1,056 words(x16) into the selected cache registers, Cache Program command (15h) instead of actual Page Program (10h) is inputted to make cache registers free and to start internal program operation. To transfer data from cache registers to data registers, the device remains in Busy state for a short period of time (t_{CBSY}) and has its cache registers ready for the next data-input while the internal programming gets started with the data loaded into data registers. Read Status command (70h) may be issued to find out when cache registers become ready by polling the Cache-Busy status bit (I/O6). Pass/fail status of only the previous page is available upon the return to Ready state. When the next set of data is inputted with the Cache Program command, t_{CBSY} is affected by the progress of pending internal programming. The programming of the cache registers is initiated only when the pending program cycle is finished and the data registers are available for the transfer of data from cache registers. The status bit (I/O5) for internal Ready/Busy may be polled to identify the completion of internal programming. If the system monitors the progress of programming only with R/B#, the last page of the target programming sequence must be programmed with actual Page Program command (10h).

Cache Program (available only within a block)

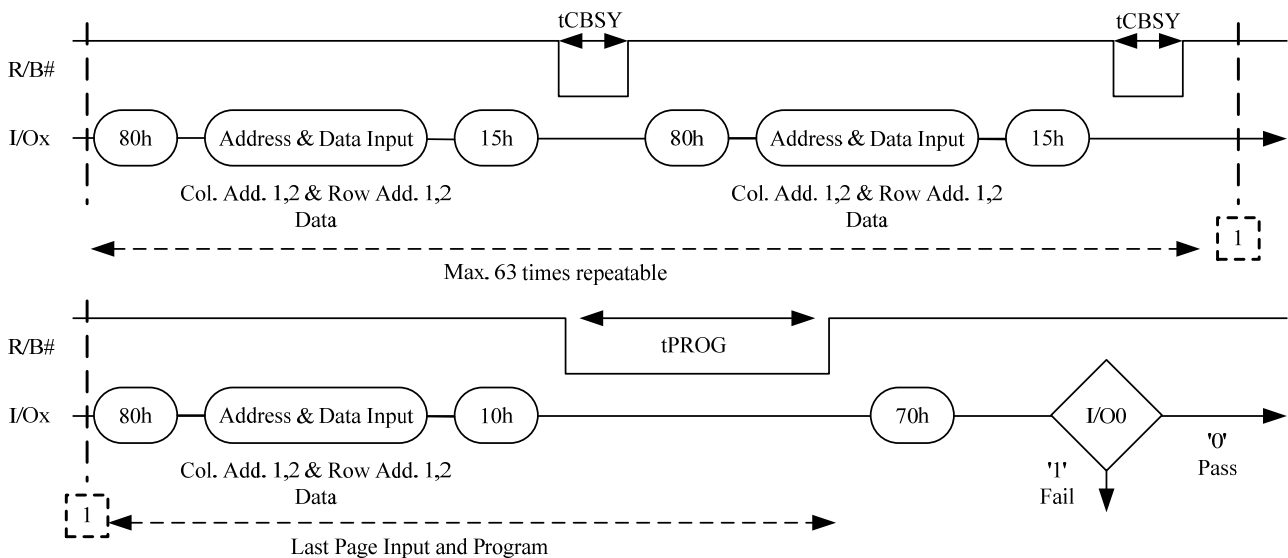

Note:

1. Since programming the last page does not employ caching, the program time has to be that of Page Program. However, if the previous program cycle with the cache data has not finished, the actual program cycle of the last page is initiated only after completion of the previous cycle, which can be expressed as the following formula.
2. $t_{PROG} = \text{Program time for the last page} + \text{Program time for the (last-1)th page} - (\text{Program command cycle time} + \text{Last page data loading time})$

Copy-Back Program

Copy-Back program with Read for Copy-Back is configured to quickly and efficiently rewrite data store in one page. The benefit is especially obvious when a portion of a block is updated and the rest of the block also needs to be copied to the newly assigned free block. Copy-Back operation is a sequential execution of Read for Copy-Back and of copy-back program with the destination page address. A read operation with “35h” command and the address of the source page moves the whole 2,112-byte(x8) or 1,056-word(x16) data into the internal data buffer. A bit error is checked by sequential reading the data output. In the case where there is no bit error, the data do not need to be reloaded. Therefore Copy-Back program operation is initiated by issuing Page-Copy Data-Input command (85h) with destination page address. Actual programming operation begins after Program Confirm command (10h) is issued. Once the program process starts, the Read Status Register command (70h) may be entered to read the status register. The system controller can detect the completion of a program cycle by monitoring the R/B# output, or the Status bit (I/O6) of the Status Register. When the Copy-Back Program is completed, the Write Status Bit (I/O0) may be checked. The command register remains in Read Status command mode until another valid command is written to the command register.

During copy-back program, data modification is possible using random data input command (85h).

Page Copy-Back Program Operation

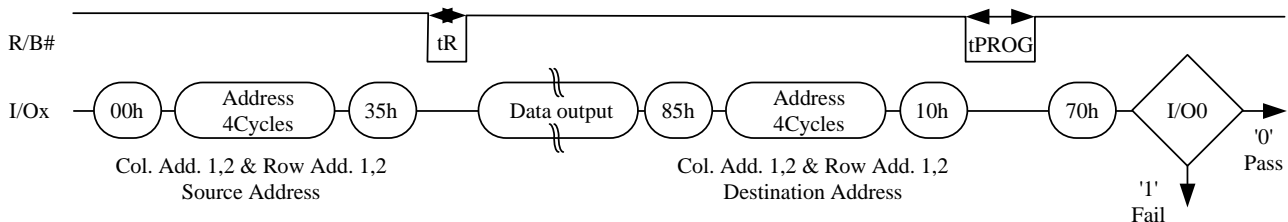

Note:

1. This operation is allowed within the same memory plane.
2. It's prohibited to operate Copy-Back program from an odd address page (source page) to an even address page (target page) or from an even address page (source page) to an odd address page (target page). Therefore, the Copy-Back program is permitted just between odd address pages or even address pages.

Page Copy-Back Program Operation with Random Data Input

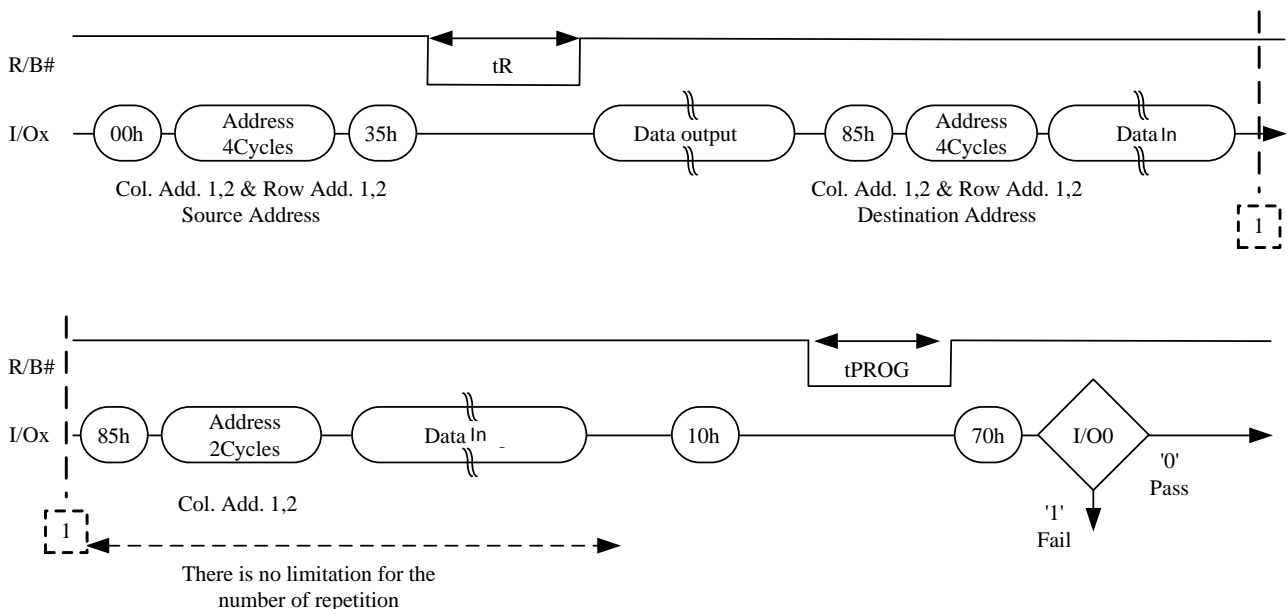

Block Erase

The Erase operation is done on a block basis. Block address loading is accomplished in two cycles initiated by an Erase Setup command (60h). Only address A₁₈ to A₂₇(x8) or A₁₇ to A₂₆(x16) is valid while A₁₂ to A₁₇(x8) or A₁₁ to A₁₆(x16) is ignored. The Erase Confirm command (D0h) following the block address loading initiates the internal erasing process. This two-step sequence of setup followed by execution command ensures that memory contents are not accidentally erased due to external noise conditions.

At the rising edge of WE# after the erase confirm command input, the internal write controller handles erase and erase-verify. When the erase operation is completed, the Write Status Bit (I/O0) may be checked.

Block Erase Operation

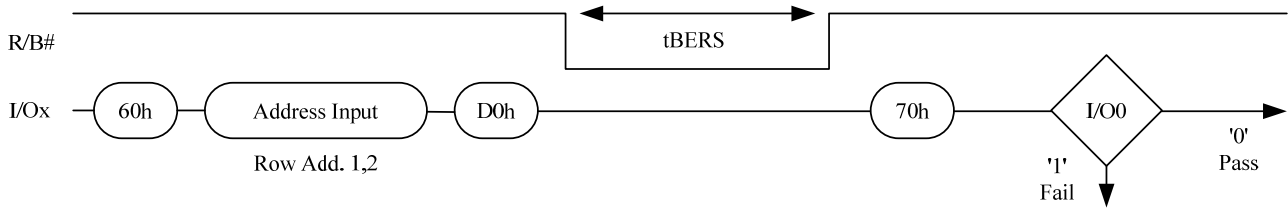

Read Status

The device contains a Status Register which may be read to find out whether program or erase operation is completed, and whether the program or erase operation is completed successfully. After writing 70h command to the command register, a read cycle outputs the content of the Status Register to the I/O pins on the falling edge of CE# or RE#, whichever occurs last. This two line control allows the system to poll the progress of each device in multiple memory connections even when R/B# pins are common-wired. RE# or CE# does not need to be toggled for updated status. Refer to below table for specific Status Register definitions. The command register remains in Status Read mode until further commands are issued to it. Therefore, if the status register is read during a random read cycle, the read command (00h) should be given before starting read cycles.

Status Register Definition for 70h Command

I/O	Page	Block	Cache	Read	Definition
I/O0	Pass/Fail	Pass/Fail	Pass/Fail(N)	Not Use	Pass:"0" Fail:"1"
I/O1	Not Use	Not Use	Pass/Fail(N-1)	Not Use	Pass:"0" Fail:"1"
I/O2	Not Use	Not Use	Not Use	Not Use	Don't cared
I/O3	Not Use	Not Use	Not Use	Not Use	Don't cared
I/O4	Not Use	Not Use	Not Use	Not Use	Don't cared
I/O5	Ready/Busy	Ready/Busy	True Ready/Busy	Ready/Busy	Busy:"0" Ready:"1"
I/O6	Ready/Busy	Ready/Busy	Ready/Busy	Ready/Busy	Busy:"0" Ready:"1"
I/O7	Write Protect	Write Protect	Write Protect	Write Protect	Protected:"0" Not Protected:"1"

Note:

1. True Ready/Busy represents internal program operation status which is being executed in cache program mode.
2. I/Os defined 'Not Use' are recommended to be masked out when Read Status is being executed.

Read ID

The device contains a product identification mode, initiated by writing 90h to the command register, followed by an address input of 00h. Four read cycles sequentially output the manufacturer code (92h), and the device code and 3rd, 4th and 5th cycle ID respectively. The command register remains in Read ID mode until further commands are issued to it.

Read ID Operation

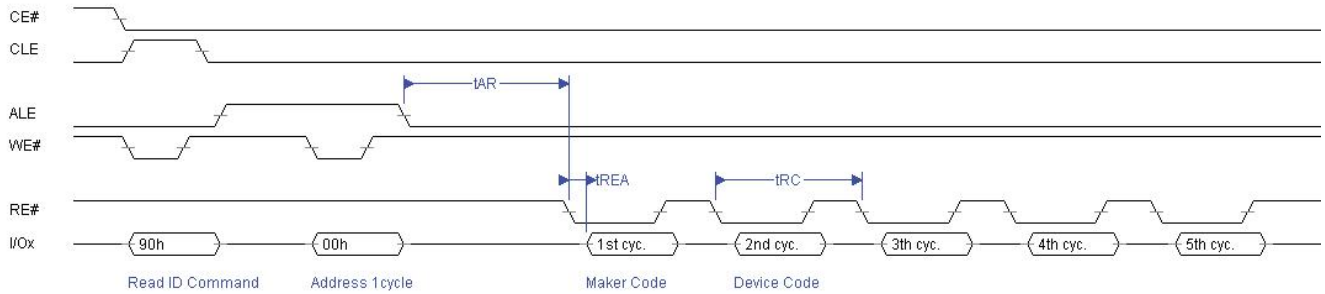

ID Definition Table

ID Access command = 90h

Option	Maker Code	Device Code	3 rd Cycle	4 th Cycle	5 th Cycle	Note
x8	92h	F1h	80h	95h	40h	
x16	92h	C1h	80h	D5h	40h	

	Description
1 st Byte	Maker Code
2 nd Byte	Device Code
3 rd Byte	Internal Chip Number, Cell Type, Number of Simultaneously Programmed Pages, Etc.
4 th Byte	Page Size, Block Size, Redundant Area Size, Organization, Serial Access Minimum
5 th Byte	Plane Number, Plane Size

RESET

The device offers a reset feature, executed by writing FFh to the command register. When the device is in busy state during random read, program or erase mode, the reset operation will abort these operations. The contents of memory cells being altered are no longer valid, as the data will be partially programmed or erased. The command register is cleared to wait for the next command, and the Status Register is cleared to value C0h when WP# is high. If the device is already in reset state a new reset command will be accepted by the command register. The R/B# pin changes to low for t_{RST} after the Reset command is written. Refer to Figure below.

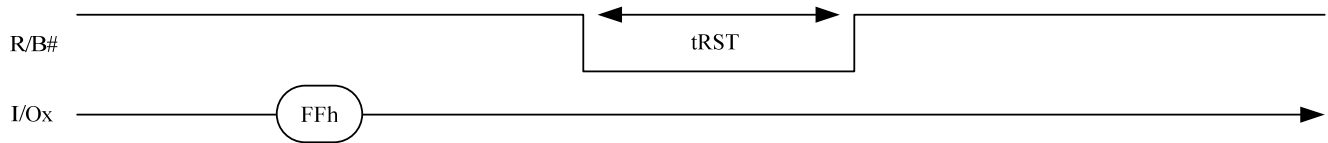

Device Status

	After Power-up	After Reset
Operation mode	00h Command is latched	Waiting for next command

READY/BUSY#

The device has an R/B# output that provides a hardware method of indicating the completion of a page program, erase and random read completion. The R/B# pin is normally high but transitions to low after program or erase command is written to the command register or random read is started after address loading. It returns to high when the internal controller has finished the operation. The pin is an open-drain driver thereby allowing two or more R/B# outputs to be Or-tied.

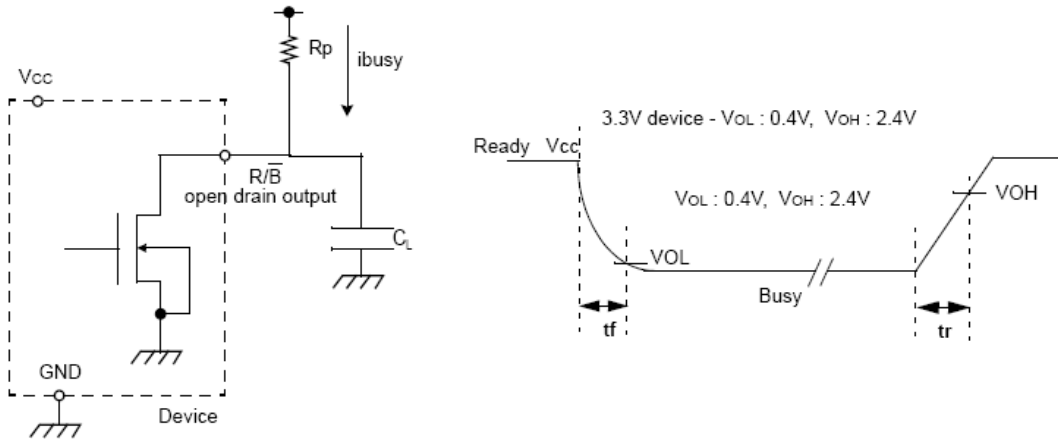
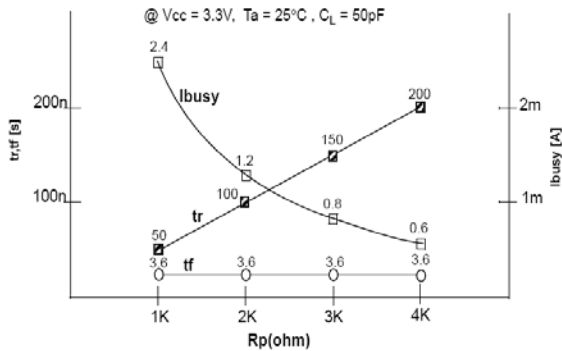
R_P vs t_{RHOH} vs C_L

R_P value guidance

$$R_p(\text{min, 3.3V part}) = \frac{V_{CC}(\text{Max.}) - V_{OL}(\text{Max.})}{I_{OL} + \sum I_L} = \frac{3.2V}{8\text{mA} + \sum I_L}$$

where I_L is the sum of the input currents of all devices tied to the R/B# pin.
R_P (max) is determined by maximum permissible limit of t_r

Data Protection & Power-up sequence

The device is designed to offer protection from any involuntary program/erase during power-transitions. An internal voltage detector disables all functions whenever V_{CC} is below about 2V. WP# pin provides hardware protection and is recommended to be kept at V_{IL} during power-up and power-down. A recovery time of minimum 100us is required before internal circuit gets ready for any command sequences as below. The two step command sequence for program/erase provides additional software protection.

AC Waveforms for Power Transition

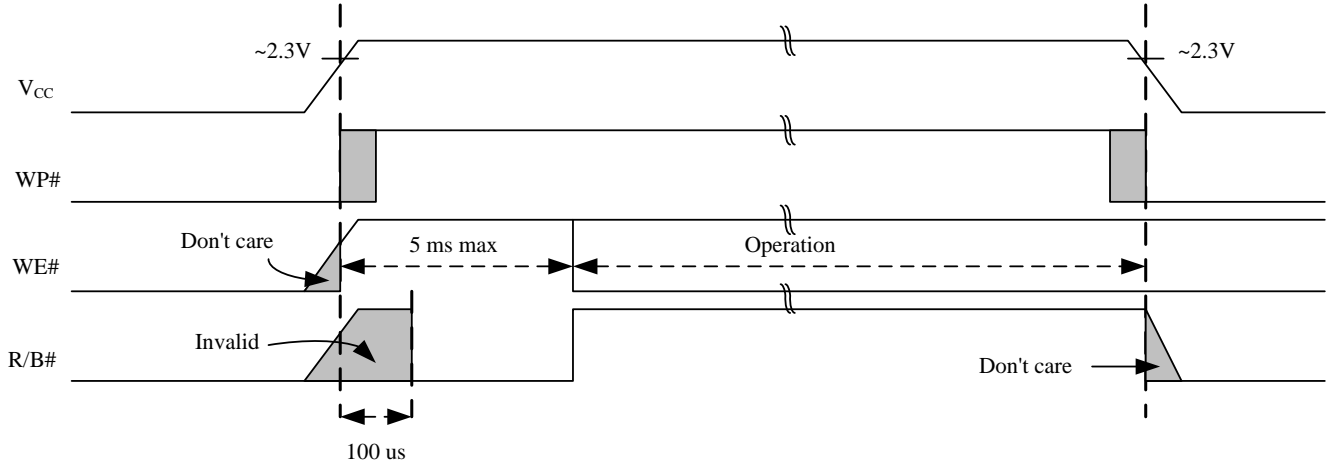

Note:

1. During the initialization, the device consumes a maximum current of I_{CC1} .

WP# AC Timing guide

Enable WP# during erase and program busy is prohibited. The erase and program operations are enabled and disabled as follows.

Program enable mode:

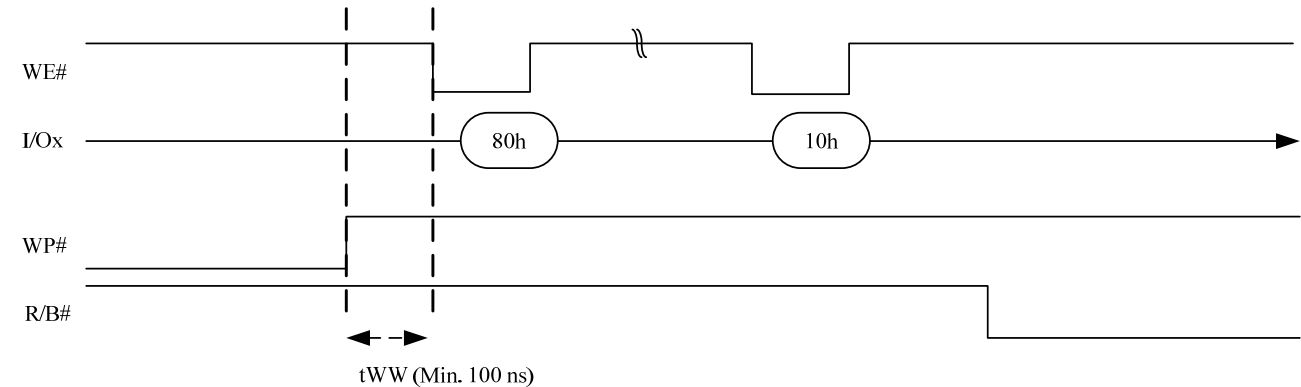

Program disable mode:

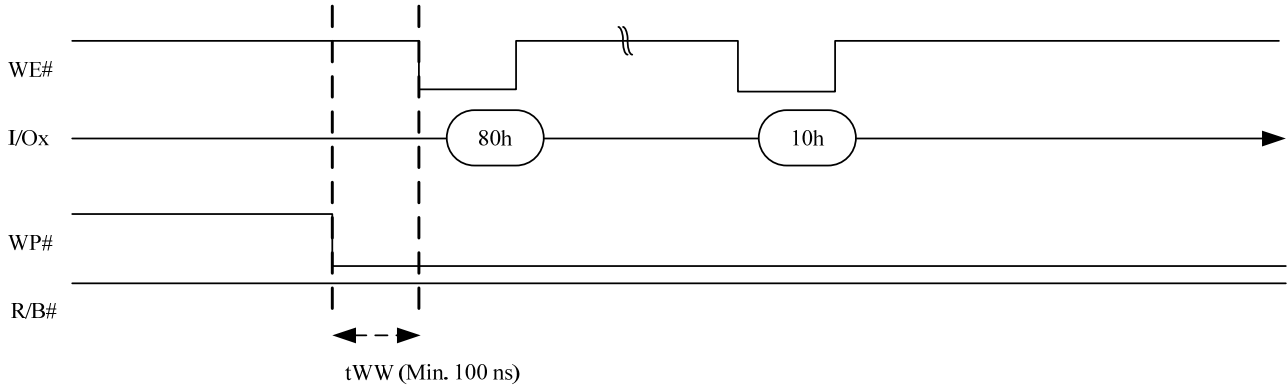

Erase enable mode:

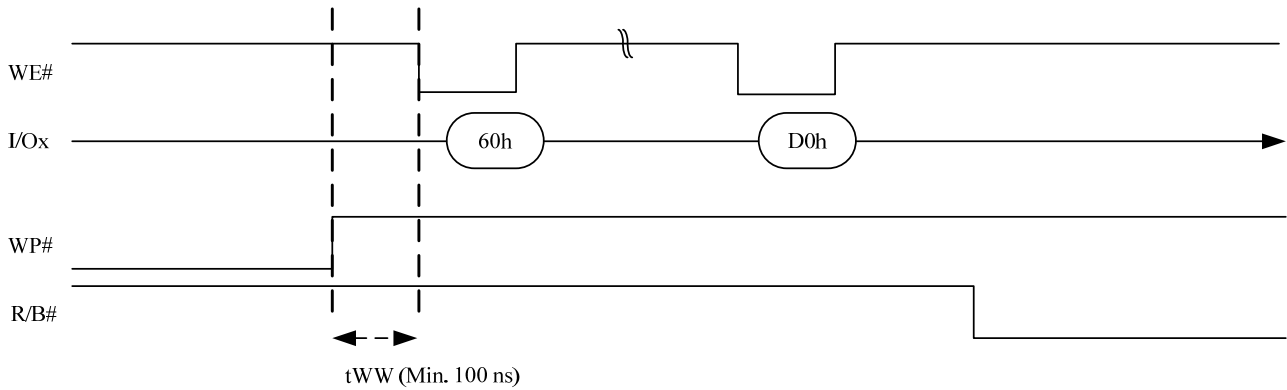

Erase disable mode:

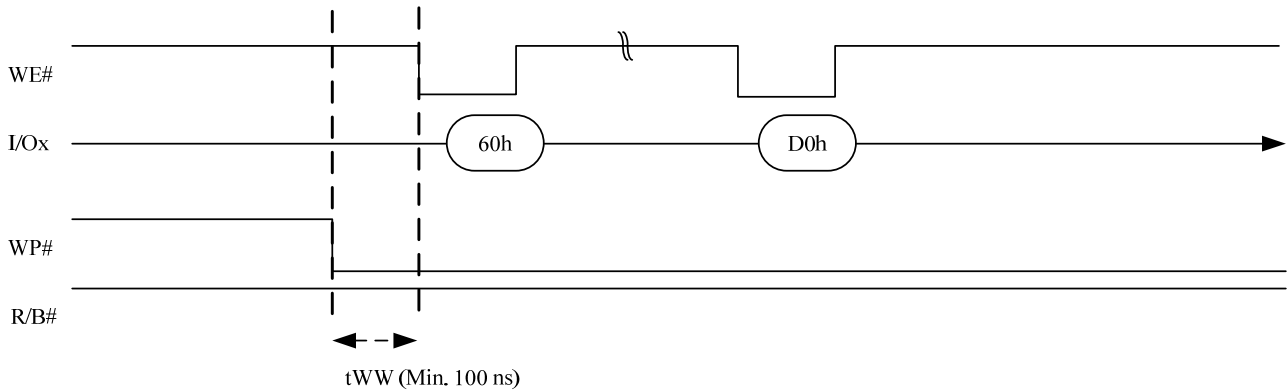

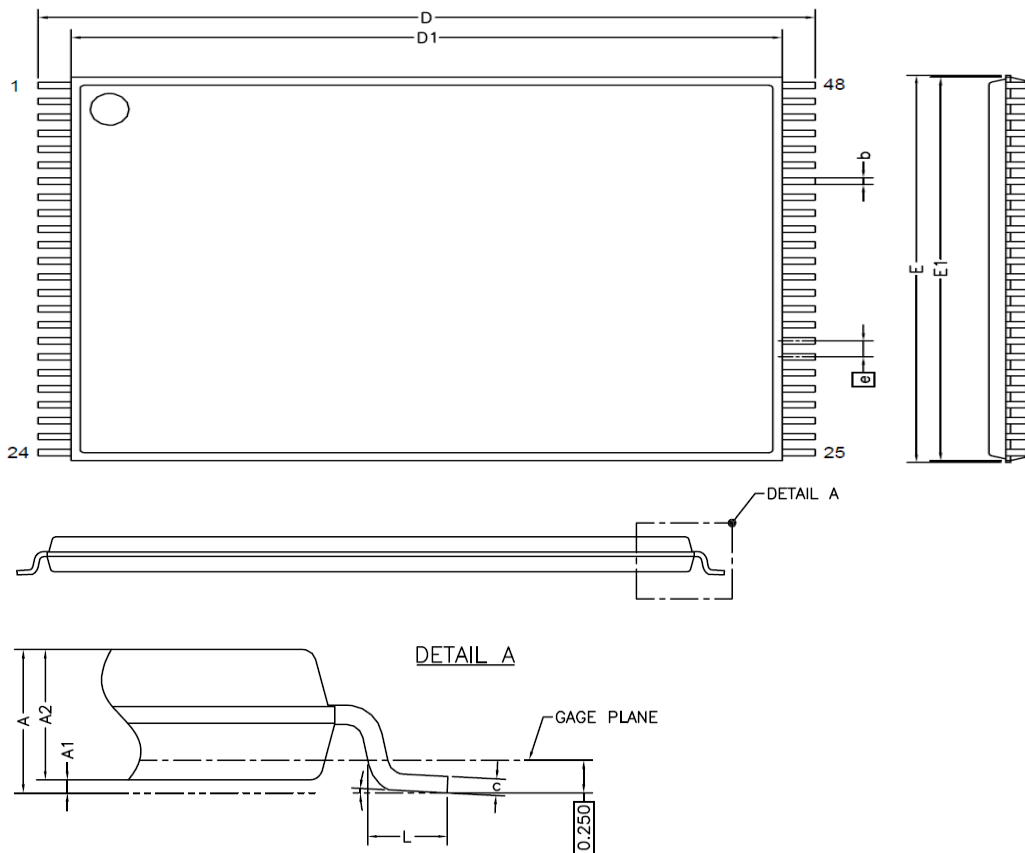
TSOP I Physical Dimensions

Symbol	Dimension (mm)		
	Min.	Typ.	Max.
A	---	---	1.20
A1	0.05	---	0.15
A2	0.95	1.00	1.05
b	0.14	0.22	0.30
c	0.10	---	0.21
D	19.80	20.00	20.20
D1	18.30	18.40	18.50
E	---	---	12.40
E1	11.90	12.00	12.10
e	---	0.50	---
L	0.50	0.60	0.70
Θ	0°	---	10°

BGA 63Ball Physical Dimensions

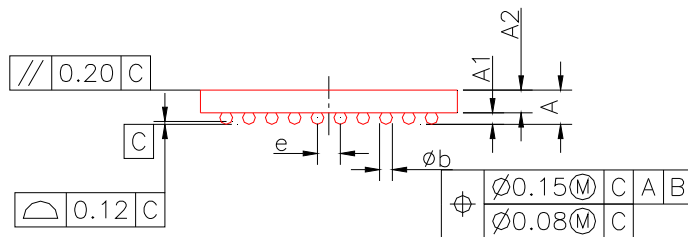
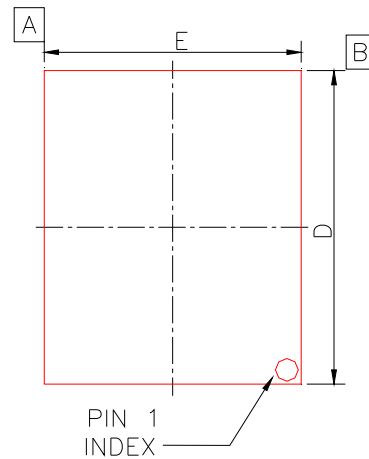
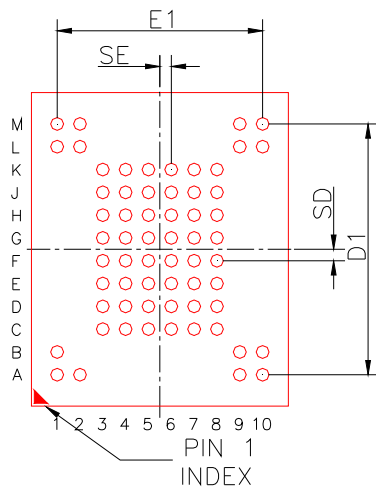

Symbol	MILLIMETERS		
	MIN.	NOM.	MAX.
A	0.85	1.00	1.11
A1	0.25	0.30	0.35
A2	0.59	0.65	0.71
D	10.9	11.0	11.1
D1	8.80 BSC		
E	8.90	9.00	9.10
E1	7.20 BSC		
b	0.40	0.45	0.50
SD	0.40 BSC		
SE	0.40 BSC		
e	0.80 BSC		



Important Notice:

Zentel products are not intended for medical implementation, airplane and transportation instrument, safety equipments, or any other applications for life support or where Zentel products failure could result in life loss, personal injury, or environment damage. Zentel customers who purchase Zentel products for use in such applications do so in their own risk and fully agree Zentel accepts no liability for any damage from this improper use.